

Holman

Instruction Guide 47993

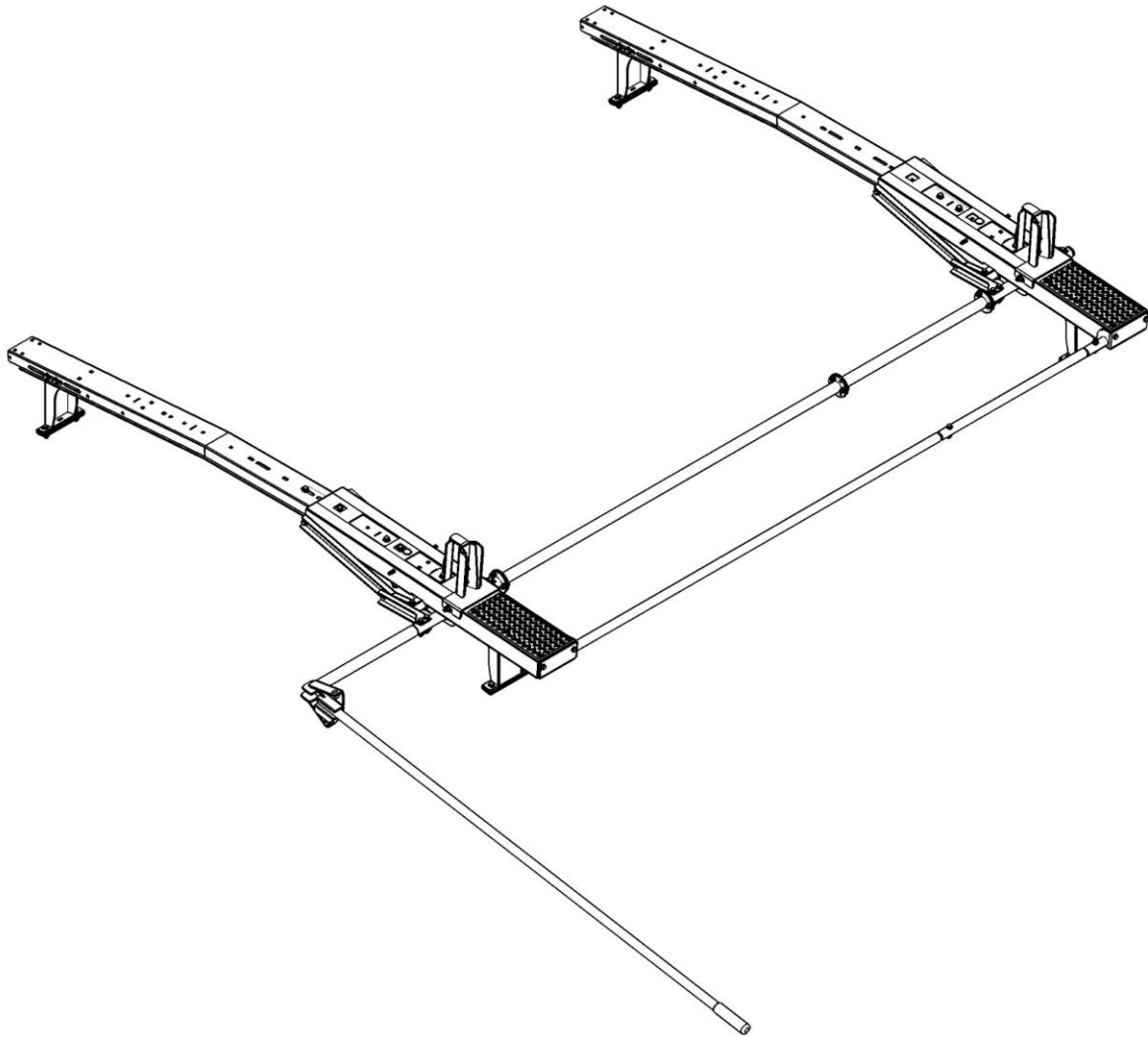

Available at Contractor's Solutions www.Contractor's Solutions.net

Holman
Rancho Cordova, CA 95742
800-343-7486
InstallationSupport@Holman.com

PLEASE READ ALL INSTRUCTIONS AND WARNINGS PRIOR TO ASSEMBLING, INSTALLING, AND USING THIS PRODUCT.

Warning



Always check for wires, fuel tanks and lines, brake lines and other important vehicle functionality items prior to drilling and installing all products.



DO NOT EXCEED MANUFACTURERS WEIGHT CAPACITY FOR ROOF.



ALWAYS REMOVE AND SECURE HANDLE BEFORE MOVING VEHICLE.

Tools Needed

5/16", 7/16", 1/2", and 9/16" Sockets	Socket Wrench
7/16", 1/2", and 9/16" Box Wrenches	1/4" and 21/64" (or Q) Size Drill Bits
Drill	Phillips Screw Driver

Table of Contents

Parts List..... 2
Hardware 3
Step 1 – Determine Installation Location 4
Step 2 – Assemble Feet..... 5
Step 3 – Identify Front and Rear Bows..... 5
Step 4 – Install Torsion Bar..... 6
Step 5 – Install Ladder Pan Stiffener 7
Step 6 – Install Handle 7
Step 7 – Determine Ladder Stop Locations..... 9
Step 8 – Install Ladder Stops 10
Step 9 – Install Ladder Hooks 10
Step 10 – Mount Rack 11
Step 11 – Install Handle Bar Holder 13
Step 12 – Test Ladder Rack 13



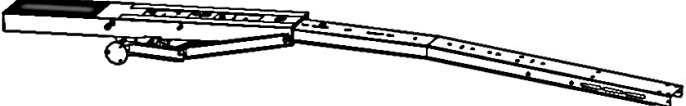
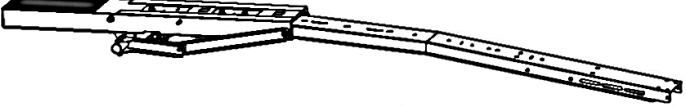
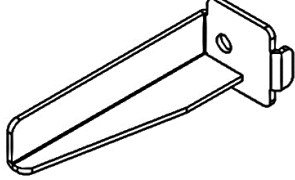
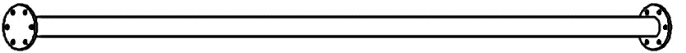
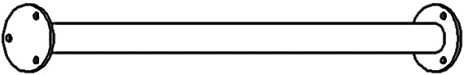
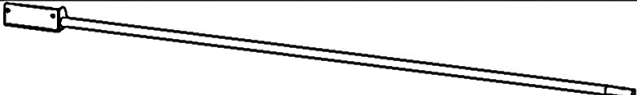
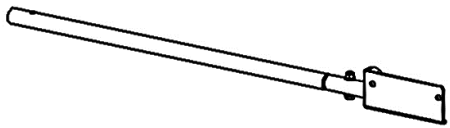
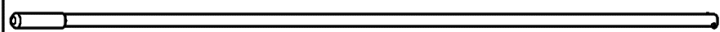
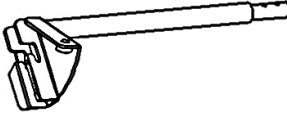
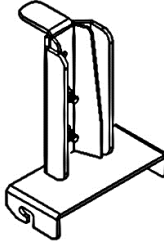
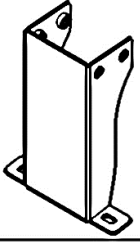
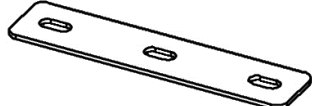

Before You Begin

- Read all instructions prior to assembling or installing any Holman rack.
- Find your vehicle roof rail mounting locations prior to rack assembly.
- **Be sure to put sealant around all threads entering cargo area and between the rubber spacer and roof of vehicle to prevent water from leaking into cargo area.**
- The standard distance between the front and rear bow is 96". This can vary, but be sure the rack can be assembled prior to installing mounts on vehicle.

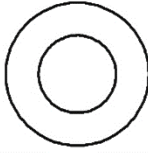
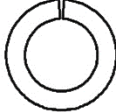
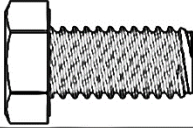
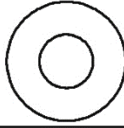

Parts List

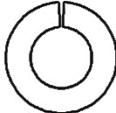
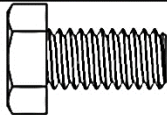
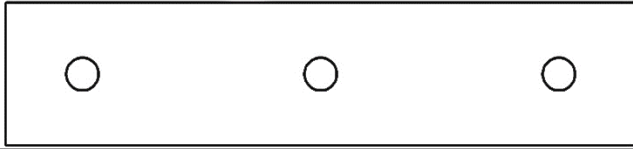
NO.	ITEM	PART NUMBER	DESCRIPTION	QTY.
1		47993-03	REAR LADDER PAN ASSEMBLY	1
2		47993-04	FORWARD LADDER PAN ASSEMBLY	1
3		40900-30-004	LADDER STOP	2
4		40993-24	TORQUE TUBE	1
5		40993-25	TOSRION TUBE EXTENSION	1
6		40993-832	STEEL LADDER PAN STIFFENER, LONG END	1
7		40993-831	STEEL LADDER PAN STIFFENER, SHORT END	1
8		40993-44	HANDLE ASSEMBLY	1
9		40993-43	ACTUATOR	1
10		40900-31	LADDER HOOK ASSY.	2
11		40959-10	SERVICE BODY FOOT-WIDE	4
12		11-03093	FLAT MOUNT BACKING PLATE	4
13		18-00805		1

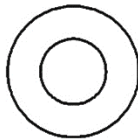
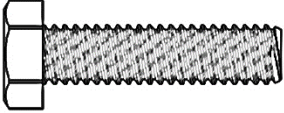
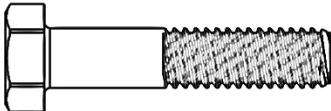
Hardware

ITEM	HARDWARE TO SCALE	PART NUMBER	DESCRIPTION	QTY.
1		0174733	3/8" STEEL FLAT WASHER	16
2		0123496	3/8" SPLIT LOCK WASHER	16
3		11241196	3/8-16 X 3/4" HEX HEAD BOLT	16
4		11545154	1/4" FLAT WASHER	18
5		13004	1/4"-20 X 7/8" HEX HEAD BOLT	9
6		70860	1/4"-20 NYLON INSERT LOCK NUT	9
7		1133620	5/16" LOCKING WASHER	4
8		92865A580	5/16"-18 X 5/8" HEX HEAD BOLT	4
9		-	RUBBER PAD-6.6x1.5	8
10		70861	5/16"-18 NYLOC	9
11		11545144	5/16" FLAT WASHER	22
12		11138690	5/16-18 X 1-1/4" HEX HEAD BOLT	8
13		11241181	5/16"-18 X 1-1/2" HEX HEAD BOLT	1

Hardware (Continued)

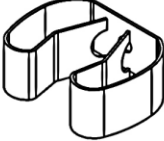
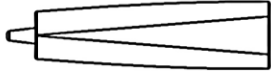
ITEM	HARDWARE TO SCALE	PART NUMBER	DESCRIPTION	QTY.
14		74803	10-24 X 5/8" PHILLIPS HEAD SCREW	2
15		37014	10-24 NYLON INSERT LOCK NUT	2
16		1723A64	Vinyl-Coated Holder, 3/4" -1-1/8" Tool Diameter	2
17		-	Self Leveling Adhesive Sealant	1

DO NOT EXCEED MANUFACTURERS WEIGHT CAPACITY FOR ROOF.

Step 1 – Determine Installation Location

- Determine the approximate location for installation of mounting feet on closed service body or cap.



The rack will require holes be drilled into the roof, so verify the following.

Make sure the following clearances and warnings are met.

- Be sure there is proper clearance inside the service body for the flat mount backing plate.
- Be sure there is there is no wiring below locations marked.
- Measure width between installation locations.

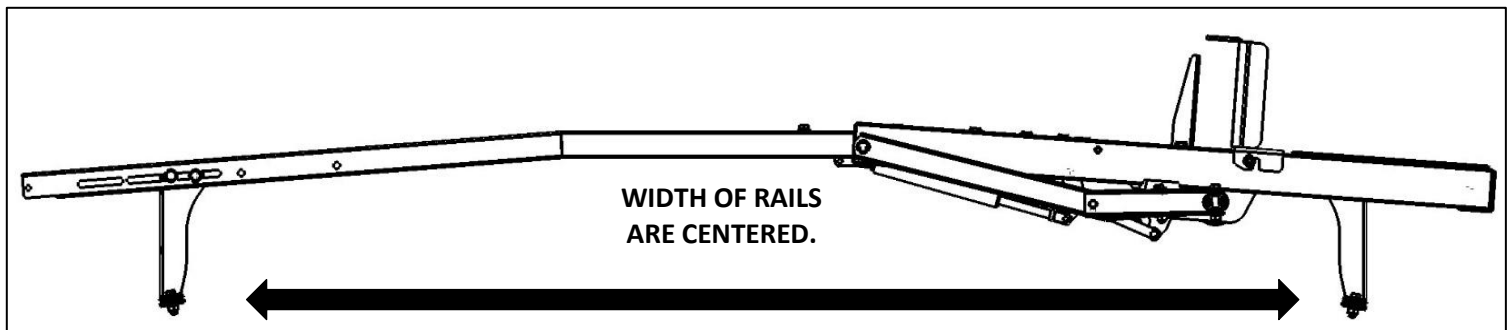

Step 2 – Assemble Feet

- On the cross bows, use the slots that correspond to the measured distance between the mounts.

NOTE: Depending on mounting width you will use either position 1 or position 2.

- Using two 3/8" x 3/4" hex head bolts, four 3/8" lock washers and four 3/8" flat washers to loosely attach foot to cross member.
- DO NOT TIGHTEN at this point.

NOTE: On Passenger Side, rotate pan out of the way to access mounting slots.

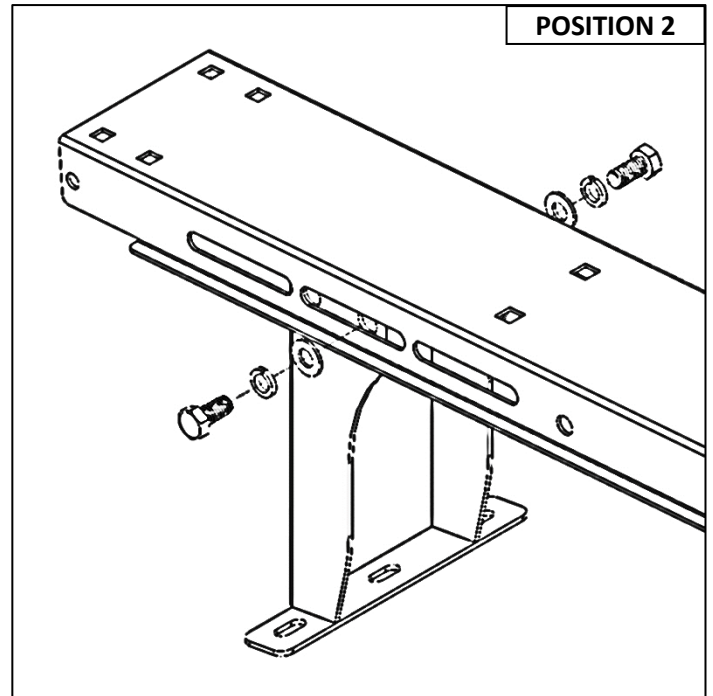
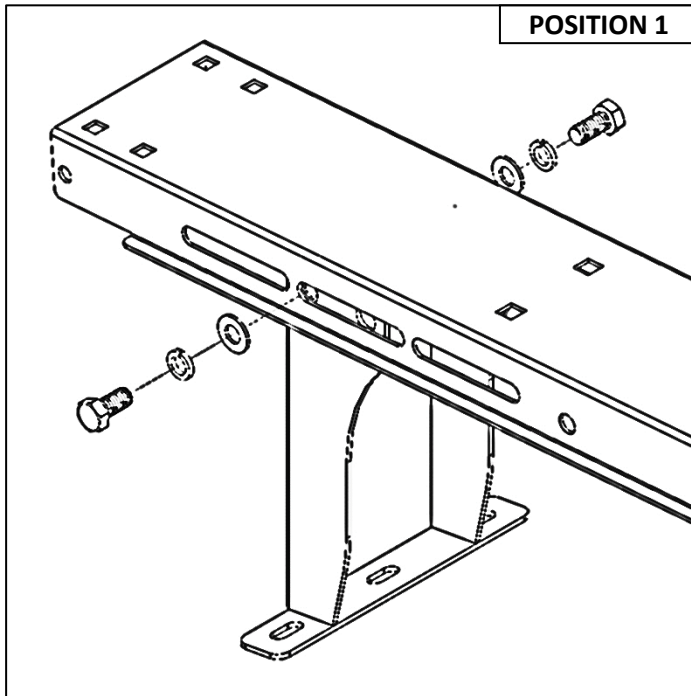

Step 3 – Identify Front and Rear Bows

- The front bow will have a cap in one end of the torsion mechanism.

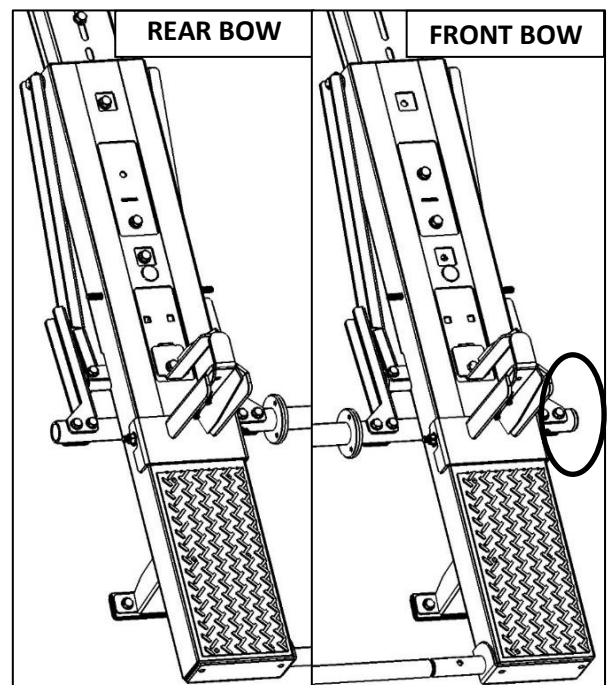

Step 4 – Install Torsion Bar

- Make sure the pan on each bow is flat against the bow.
- Using three 1/4" x 7/8" hex head screws, six 1/4" washers, and three 1/4" lock nuts, attach one end of the torsion tube extension to the front bow as shown below.

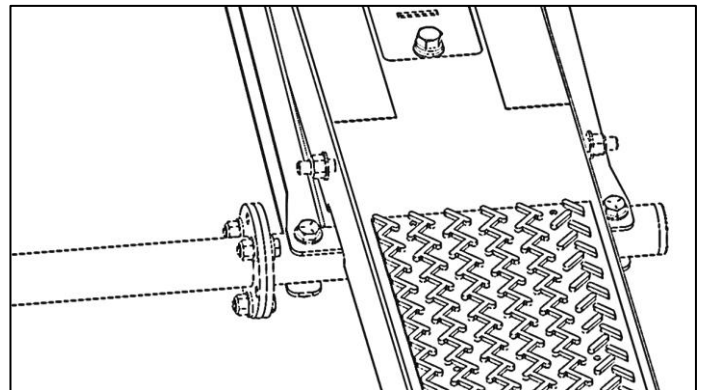
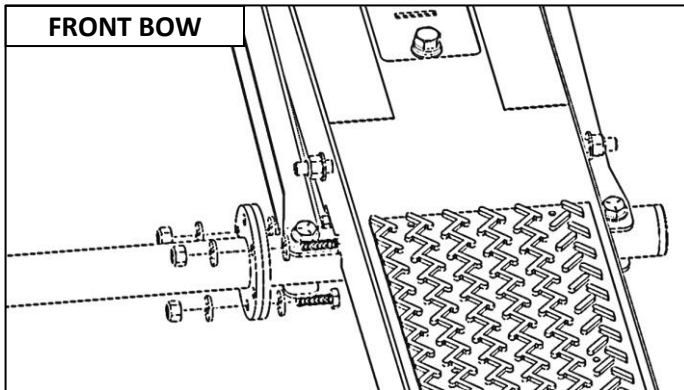

- Using three more 1/4" x 7/8" hex head screws, 1/4" washers, and 1/4" lock nuts, attach the opposite end of the torsion tube extension to the torsion tube as shown below.

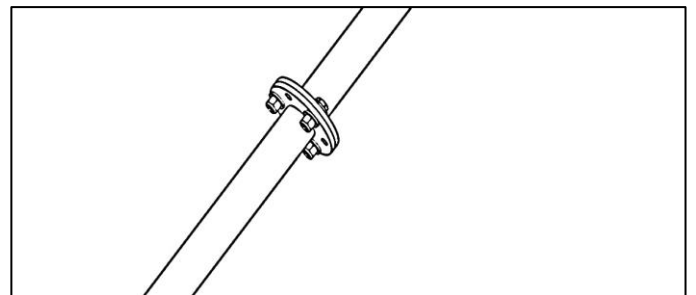
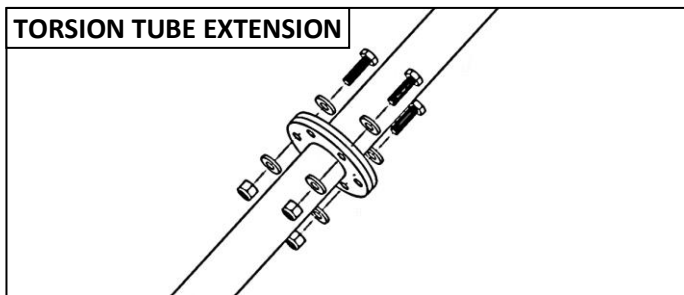

- Using three more 1/4" x 7/8" hex head screws, 1/4" washers, and 1/4" lock nuts, attach the opposite end of the torsion tube to the rear bow as shown below.

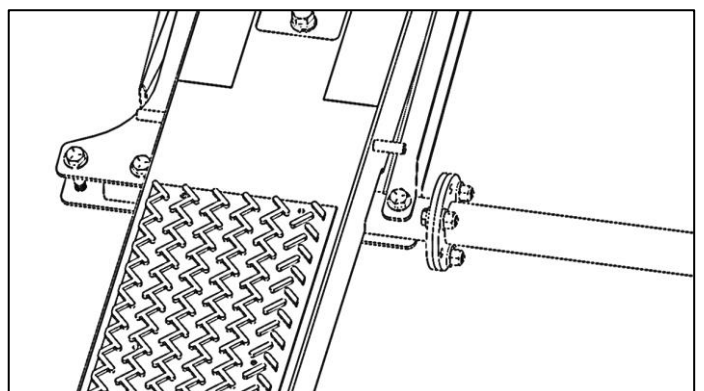
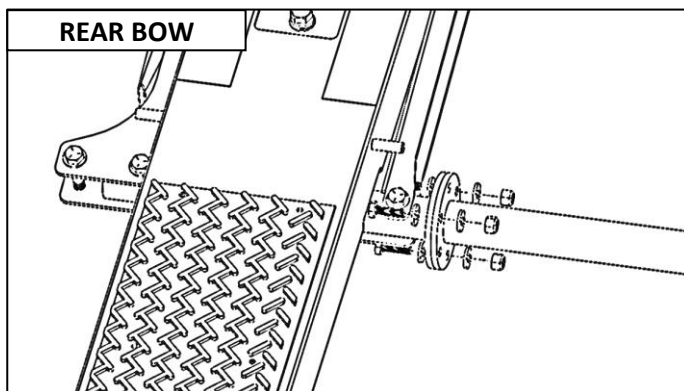

Step 5 – Install Ladder Pan Stiffener

- Insert swaged end of ladder pan stiffener long end into ladder pan stiffener short end aligning holes.
- Fasten ladder pan stiffener long end to ladder pan stiffener short end using 5/16" x 1-1/2" hex head screws, 5/16" washers, and 5/16" lock nuts.

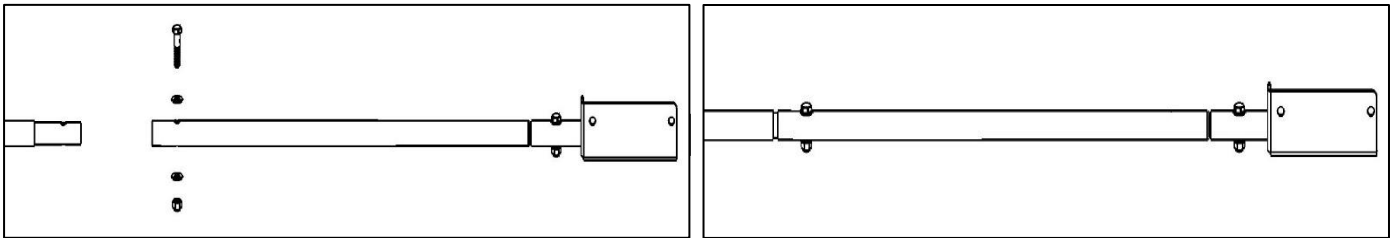

- Using two 5/16" x 5/8" hex head bolts, 5/16" lock washers, and 5/16" washers, attach each end of the ladder pan stiffener to the pans.

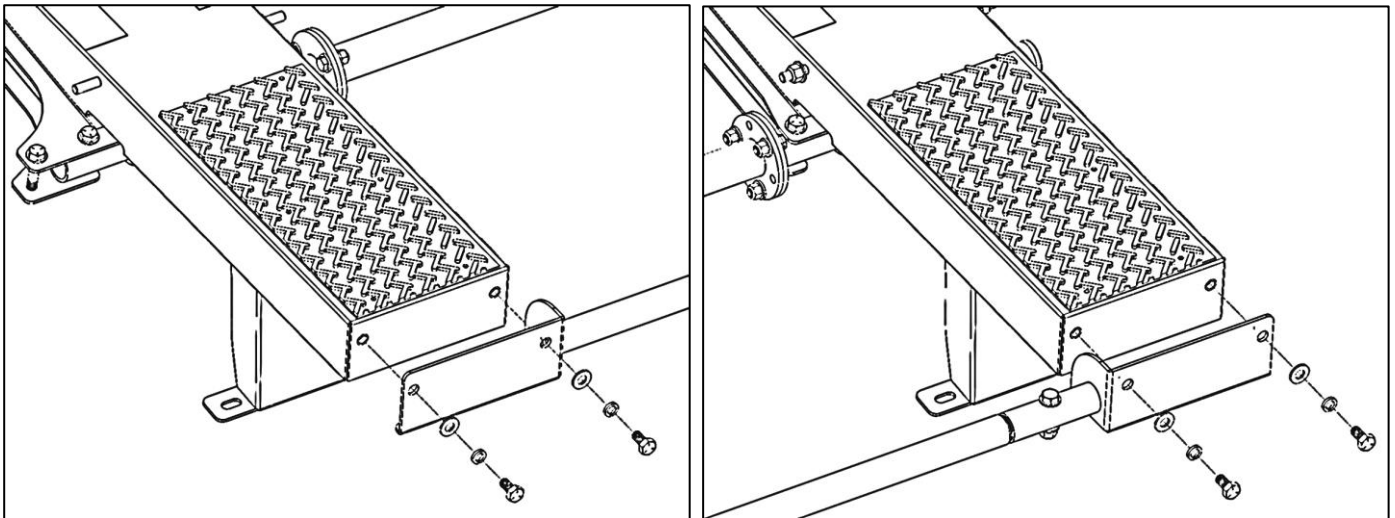

Step 6 – Install Handle

- Remove the two 5/16" x 2" flanged head screw, four 5/16" washers, and two 5/16" lock nuts from front bow as circled below.
- Insert swaged end of operator arm into the torsion mechanism so the holes in the handle tube line up with the holes in the torsion mechanism on the front ladder pan.

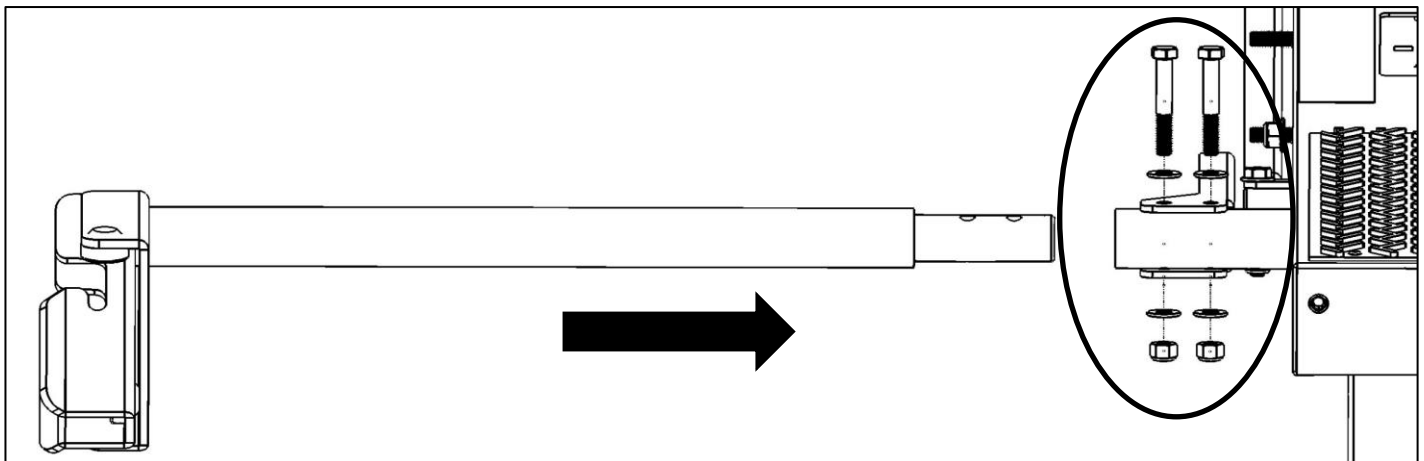

- Fasten operator arm to torsion mechanism using the previously removed 5/16" x 2" flanged head screws, 5/16" washers, and 5/16" lock nuts.
- TIGHTEN bolts and nuts.

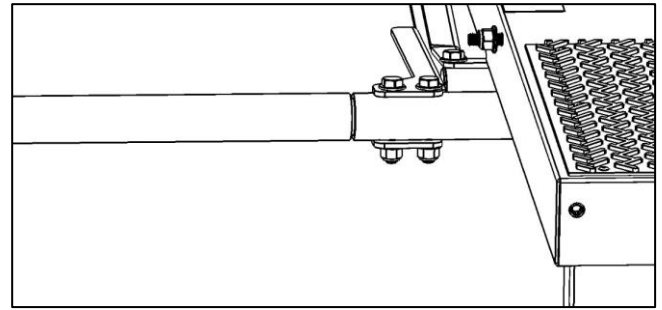

- Attach handle into operator arm by pushing handle in and then pulling out.



ALWAYS REMOVE HANDLE BEFORE MOVING VEHICLE.

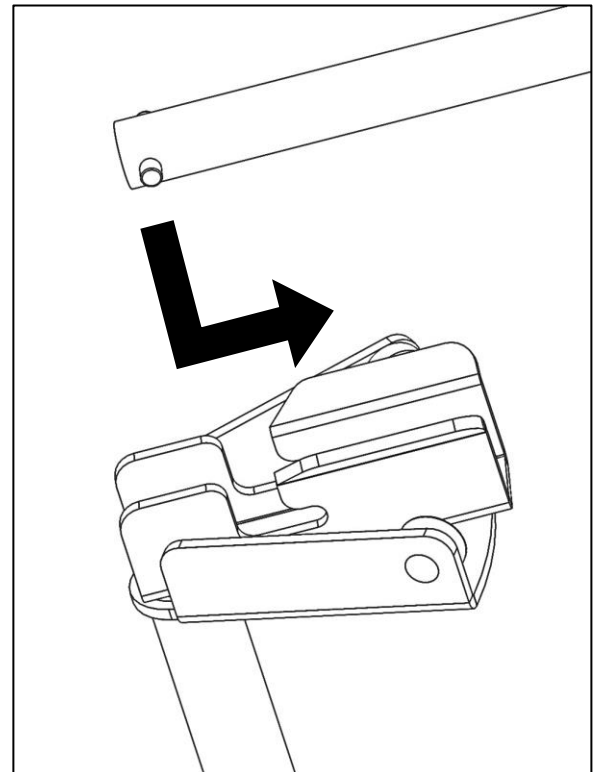
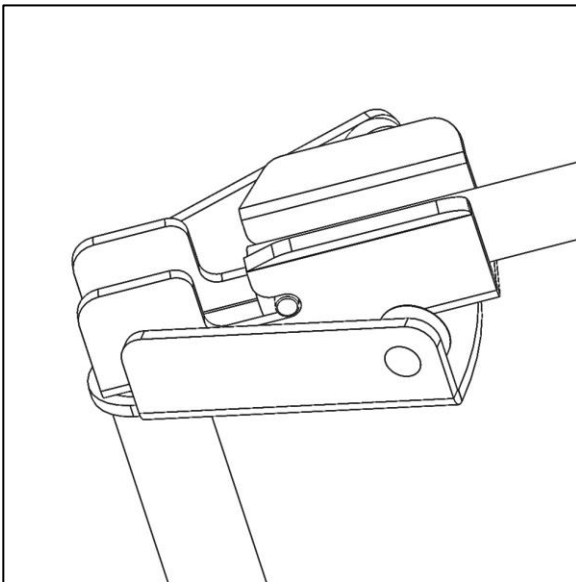

Step 7 – Determine Ladder Stop Locations

NOTE: On each bow, there are two positions available for mounting the ladder stops and ladder hooks based on the size and type of ladder. Ladder stops may be installed either further inboard or further outboard, depending on the ladder to be used. It is best to determine the size and type of ladder prior to installing the ladder stops and ladder hooks. The following are examples of a typical 8 foot stepladder and 10 foot extension ladder mounted on the drop down ladder rack.

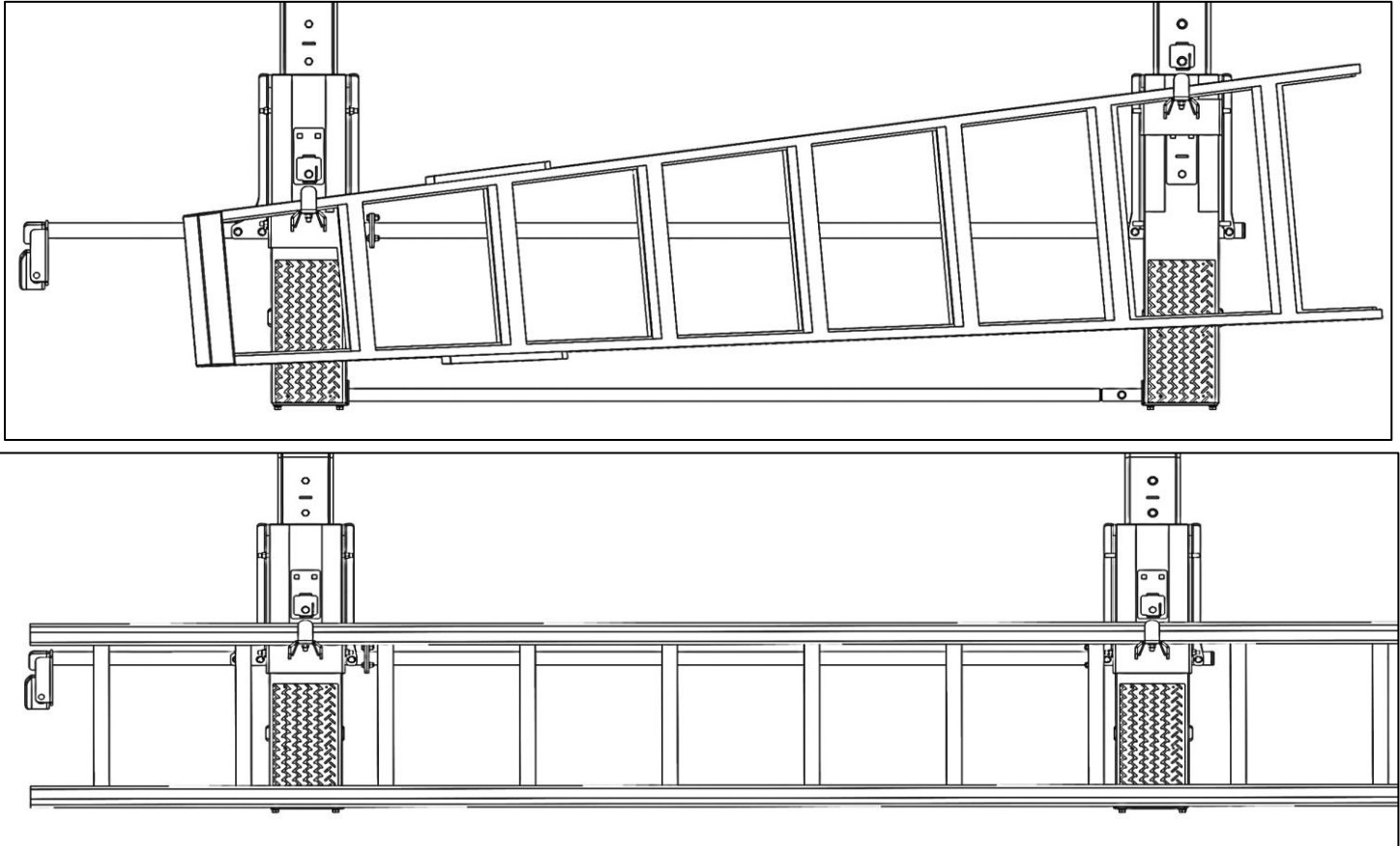

The following are the two positions available on each bow.

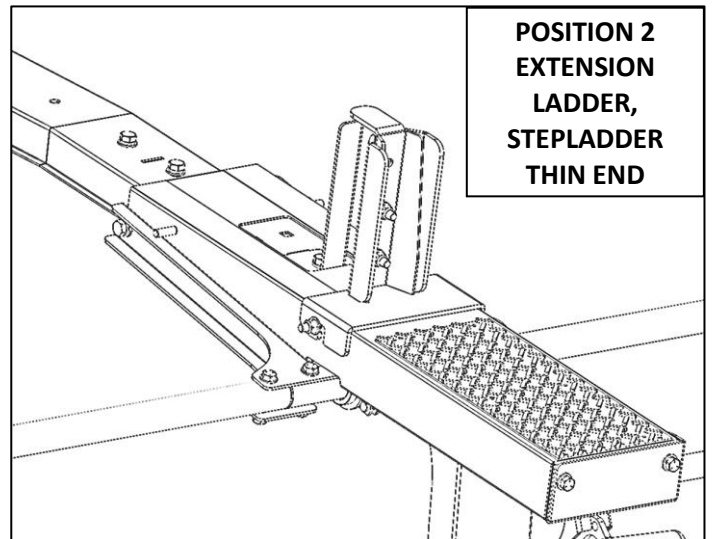
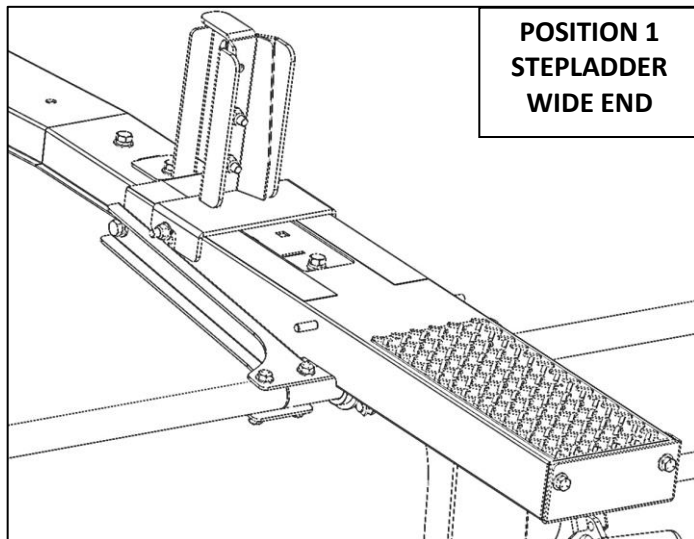

Step 8 – Install Ladder Stops

- Using the hardware in the front bow, bolt ladder stop in orientation shown below. Be sure to place the tab on the ladder stop into the slot on the bow.
- Repeat for rear bow.
- TIGHTEN hardware.

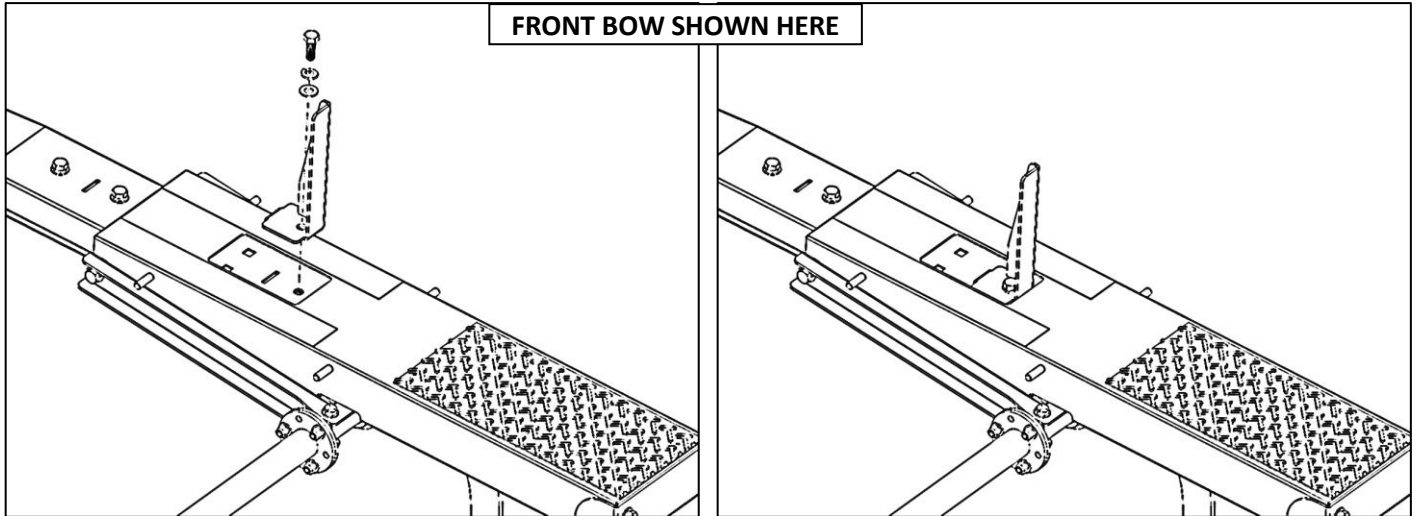

Step 9 – Install Ladder Hooks

- Using the installed studs and lock nuts on both bows, loosen nuts and slide ladder hook assembly into place.
- TIGHTEN lock nuts.

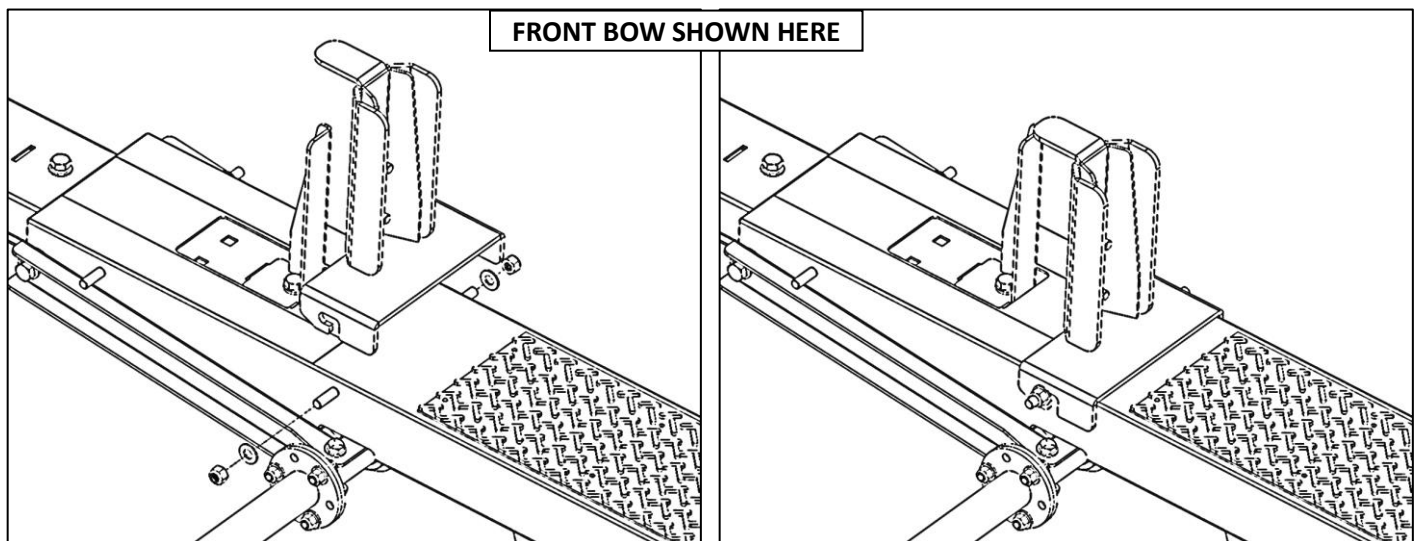

Step 10 – Mount Rack

- Set rack on top of service body and center rack side-to-side and square to the vehicle.

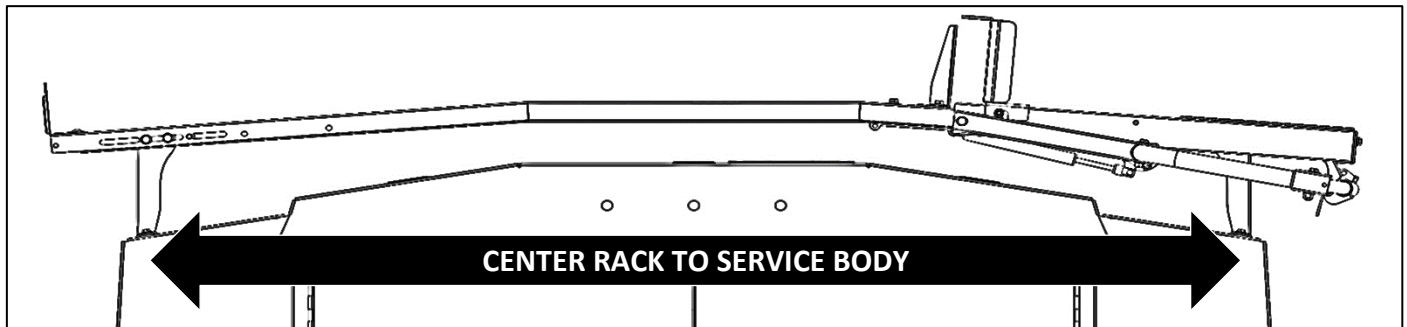

Make sure the following clearances and warnings are met.

- Be sure front bow is towards front of the vehicle and handle is towards rear of vehicle.
 - Be sure there is adequate clearance behind service body for the handle and to properly actuate the drop down mechanism.
 - Be sure there is proper clearance inside the service body for installation of the flat mount backing plates.
 - Be sure there is there is no wiring below installation locations that may interfere with drilling and installation.
- Mark onto the top of the service body the locations of holes in bottom of mounting feet.
 - Remove rack from service body.
 - Using a 21/64" or Q drill bit, drill holes in the top of the service body where marked.

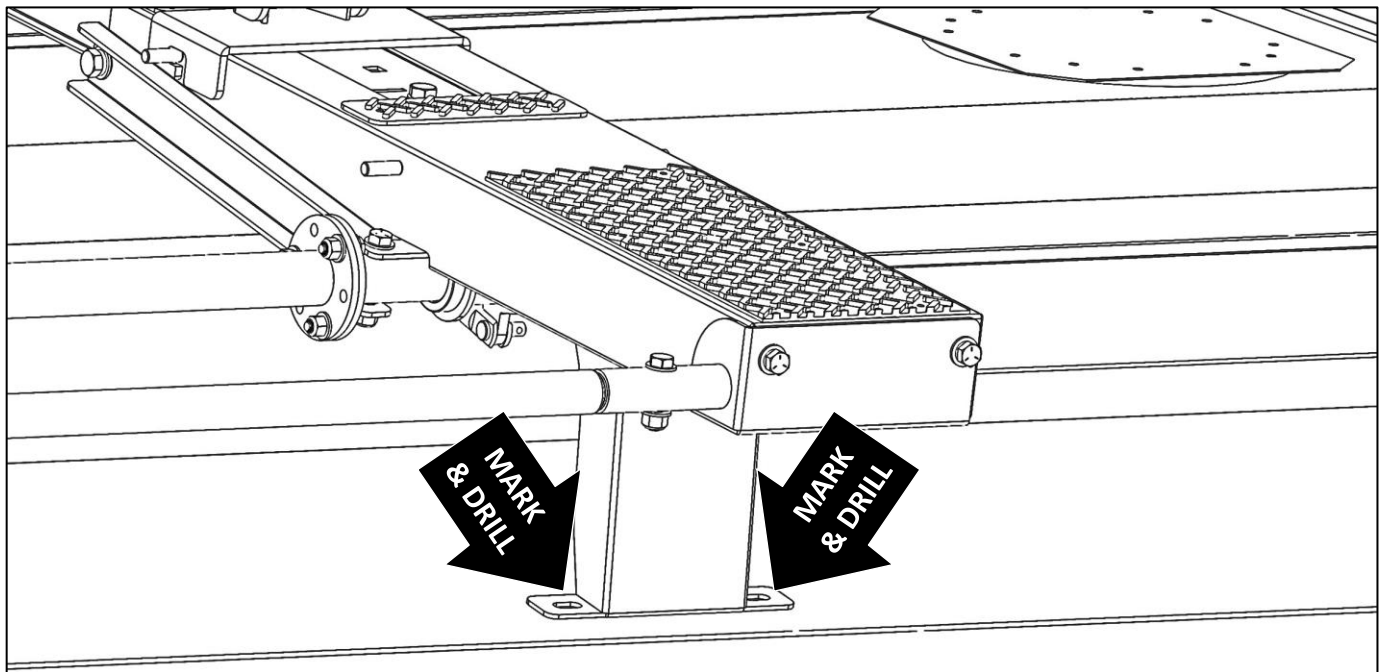

- Set rack on top of service body and align rack to holes drilled.
- Using two of the three-hole rubber pads, one 5/16" x 1-1/4" hex bolt, two 5/16" flat washers and two 5/16" lock nut, secure each foot to the service body. Apply sealant to bottom of upper rubber pad and around bolts.

- Snugly tighten, but allow movement.

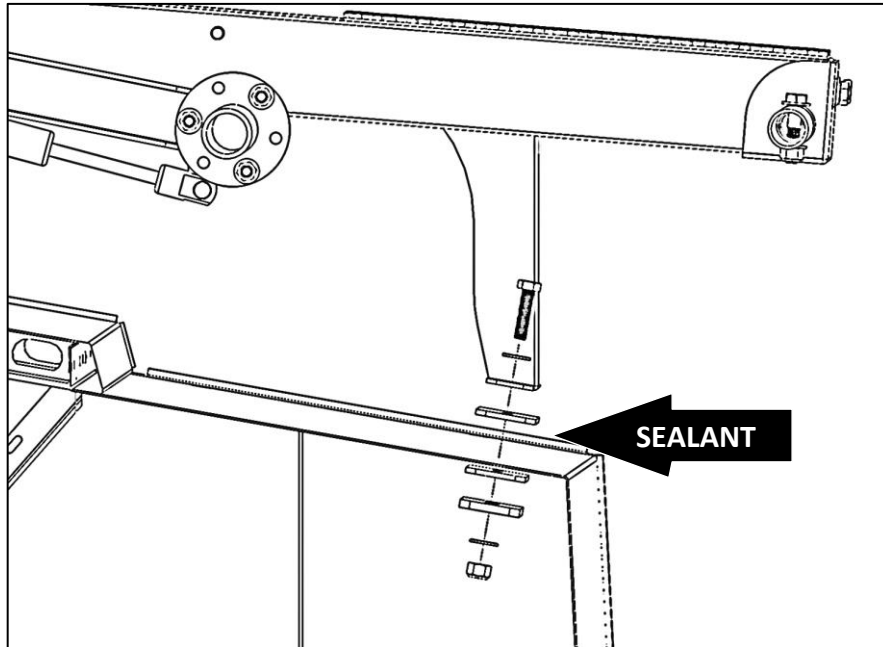

- **Verify rack works appropriately.**
- Additional 3/8" hardware has been provided for secondary fastening of feet to bows. If self-clinching nuts are accessible after installation, it is recommended to apply the additional hardware.

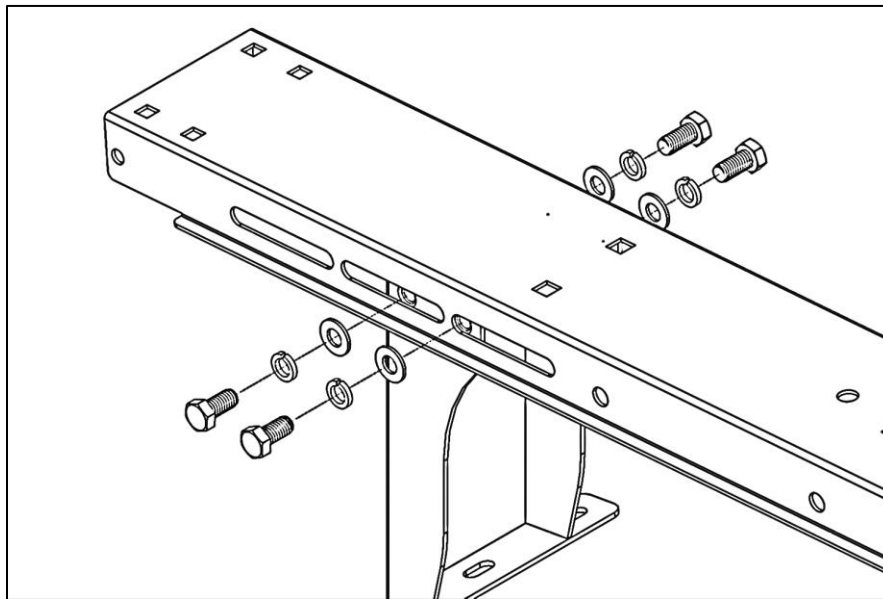

Step 11 – Install Handle Bar Holder

- Determine best location for the installation of the handle bar. Most installs are at the rear of the van, on the backside of a shelving unit. This makes it easily accessible when the rear doors are open.
- Drill a 1/4" hole in desired locations.
- Install clips using #10 hardware provided.

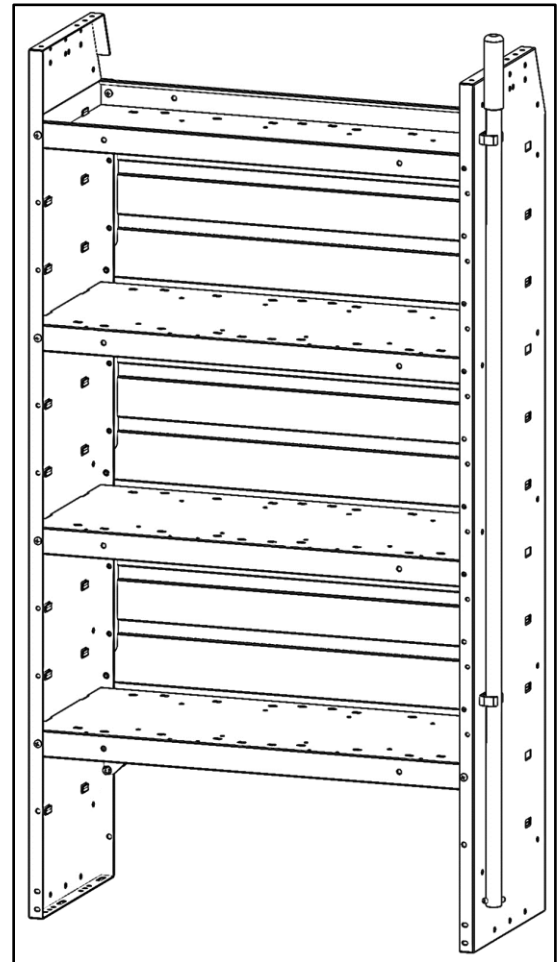
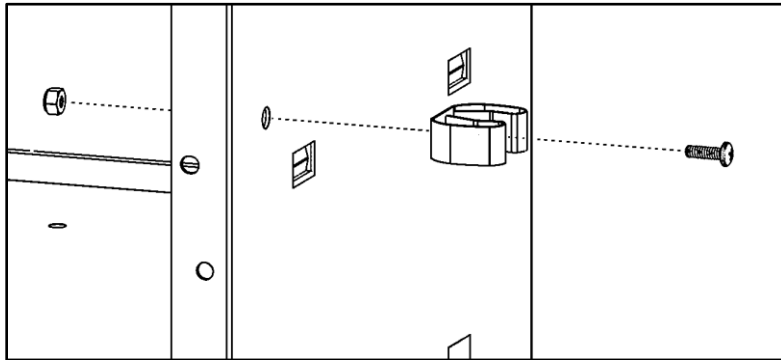

**GO BACK AND ENSURE ALL
HARDWARE IS TIGHT.**

Step 12 – Test Ladder Rack

- Prior to installing a ladder, place the long handle into the handle bar assembly and test that the ladder rack mechanism works correctly. Actuating handle requires pushing handle against rubber bumper built into operator arm.
- If necessary, re-align and re-square rack.

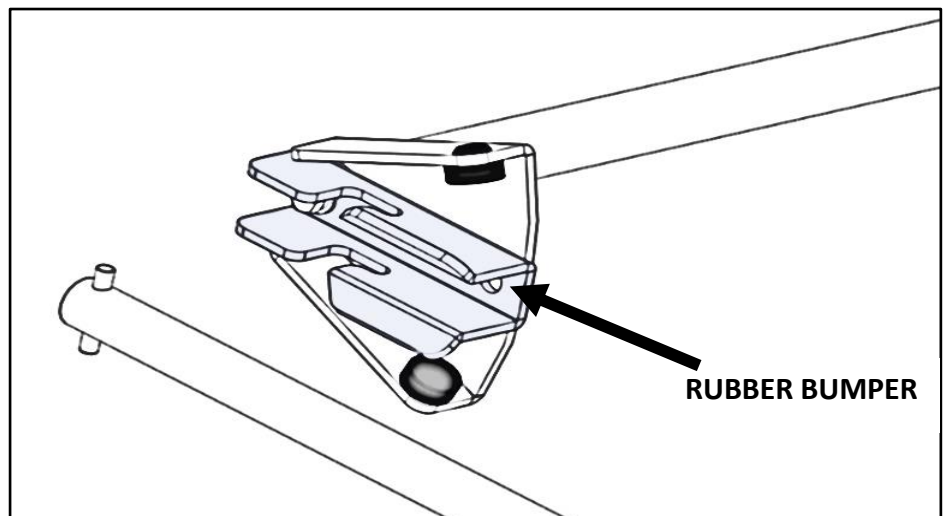

ASSEMBLY AND INSTALLATION ARE COMPLETE.