



Beech

Engineering & Manufacturing

B-1000

1000 lb capacity

Standard oversize roller bearing phenolic 5"x 2" load wheels and 4"x 2" steering casters provide ease of movement

Each machine is factory proof tested to 150% of load

Safety swivel hook is attached directly to boom

Safety by-pass relief valve is standard to prevent dangerous overloading

Optional floor lock available



2 year warranty on entire machine, 5 year on frame weldment

P.O. Box 947 • New Philadelphia, Ohio 44663 • Phone 1-800-726-9491 • Fax 330-343-3037

www.beechengineering.com

A Division of



Model B-1000 Hydraulic Floor Crane

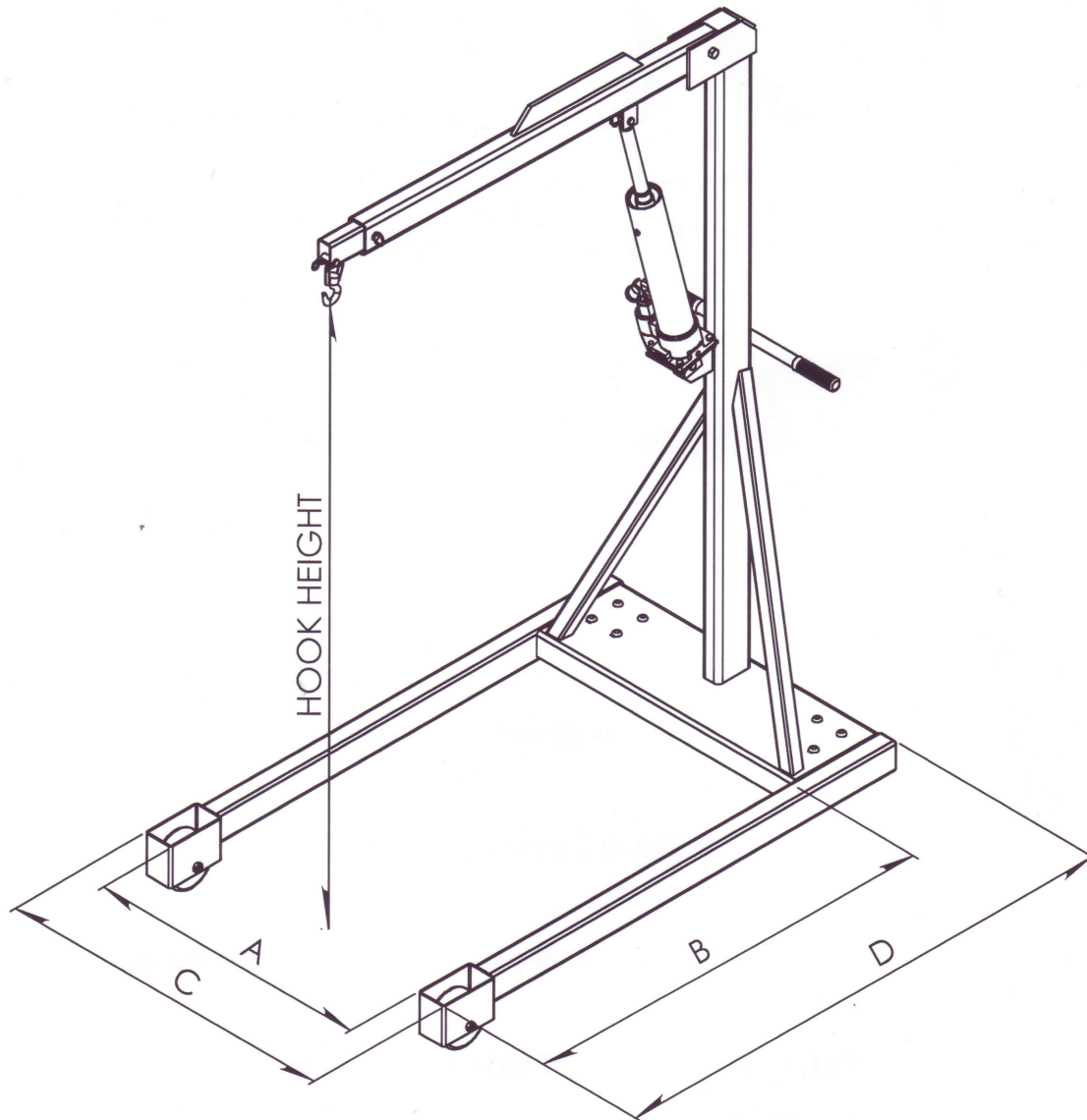

Model No.	Pump Type ¹	Machine Weight	Boom Position ²	Hook Capacity	Hook Height ³		Dimensions				
					Min	Max	A	B	C	D	OAH
B-1000	Single Speed Manual	200 lbs.	38 1/2"	1000 lbs.	30"	105"	28"	43"	35 7/8"	53 1/8"	71 7/8"
			44 1/2"	750 lbs.	25"	110"					
			50 1/2"	450 lbs.	20"	116"					
			56 1/2"	200 lbs.	15"	121"					

¹ Pump is equipped with internal load relief to protect both load and crane.

² Measured from the front of base channel to centerline of load hook.

³ Add 7" to maximum hook height to assure overhead clearance.

Beech Engineering & Manufacturing
P. O. Box 947 * New Philadelphia, Ohio 44663 * Phone 800-726-9491 * Fax 330-343-3073
www.beechengineering.com