



# Sectional and Utility Scaffold



[www.Contractors-Solutions.net](http://www.Contractors-Solutions.net)

# Know Your Scaffold / Safety / Decals

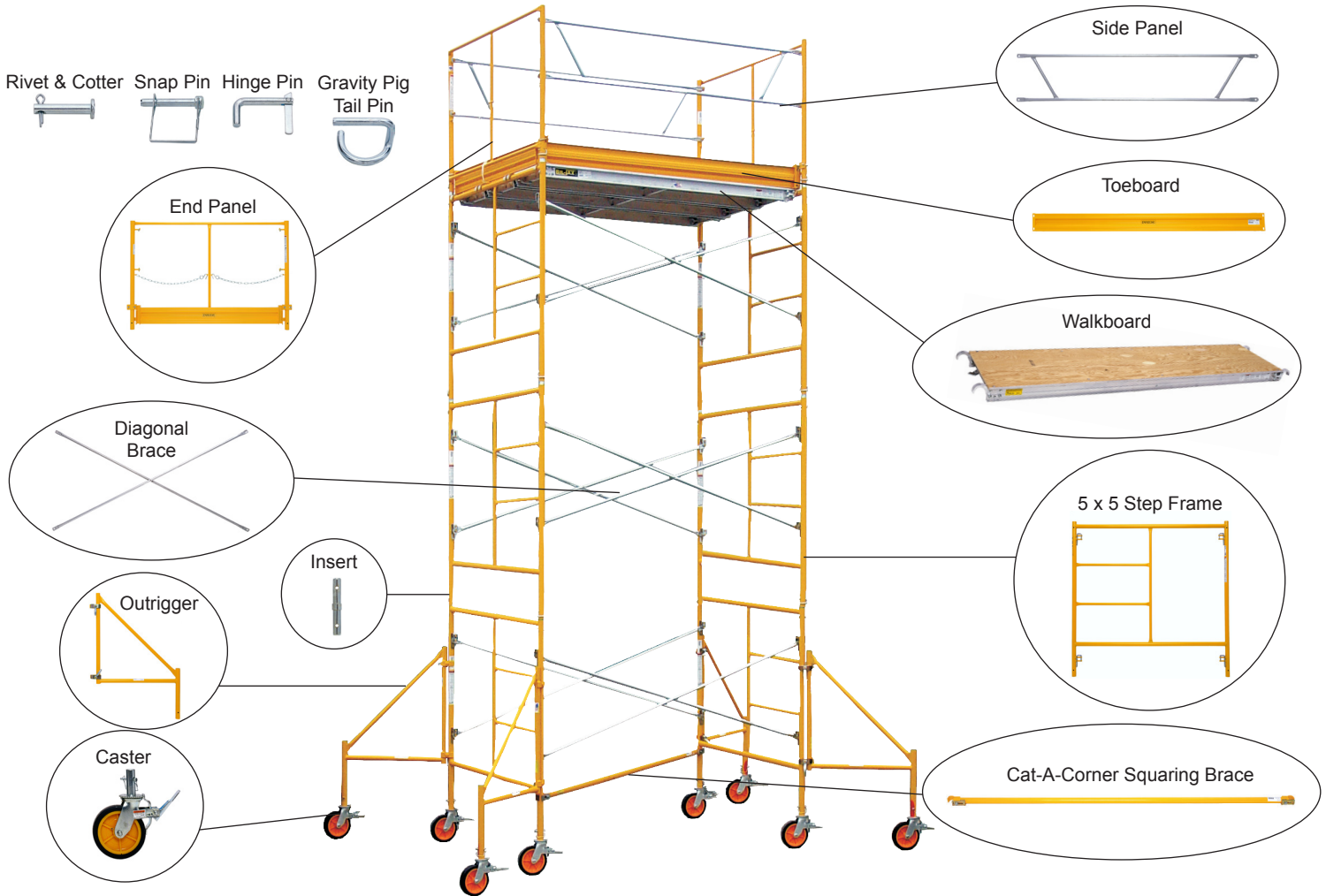

## SAFETY

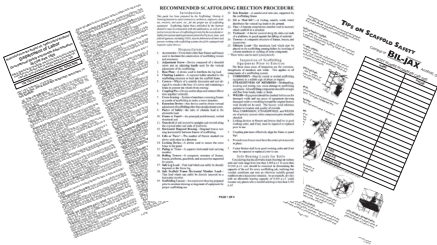

Part Number	Description
LL-204-01	Tips on scaffold safety / safety rules
LL-204-02	OSHA safety and health regulations for construction
LL-204-03	Recommended scaffold erection procedures
LL-204-04	Caution envelope with wire
LL-204-05	Scaffold safety packet (includes - LL-204-01, LL-204-02, LL-204-03, LL-204-04, LL-204-11)
LL-204-11	Instructions for erecting rolling towers
LL-204-22	Commitment to safety package (includes - 1 Scaffold safety video, 20 frame decals, 25 LL-204-05 scaffold safety packets, and a laminated certificate.
LL-204-27	Scaffold check guide cards

## REPLACEMENT DECALS

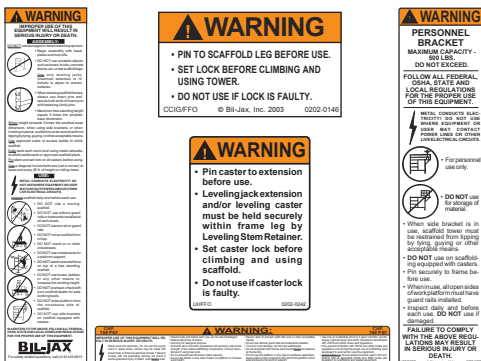

Part Number	Description
0202-0101	Panel guard warning decal
0202-0146	Caster decal (used on all BilJax casters)
0202-0242	Leveling caster / leveling jack extension decal
0202-0326	Scaffold frame warning decal
0202-0328	Personnel bracket warning decal
0202-0330	Guard railing decal
0202-0331	Walkboard / catwalk warning decal (Tuf-N-Lite)
0202-0335	Hoist arm warning decal
0202-0361	Expanded metal walkboard / catwalk decal

# Frames

## Frame Tube Sizes

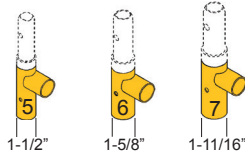

Tube Size	Description
5	Frame with 1 1/2" Leg O.D. (weighs 10% less than catalog listings)
6	Frame with 1 5/8" Leg O.D. (weighs same as catalog listings)
7	Frame with 1 11/16" Leg O.D. (weighs 5% more than catalog listings)

## Frame Lock Types

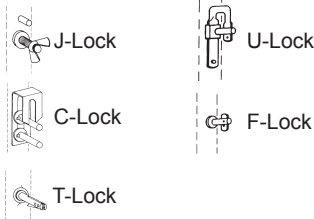

Lock Type	Description	Lock Number
J-Lock	J-Lock use with notched braces	1
C-Lock	C-Lock use with holed braces	2
T-Lock	T-Lock use with holed braces	4
U-Lock	U-Lock use with holed braces	8
F-Lock	F-Lock use with holed braces	5

## STEP FRAMES - specify tube size and lock type

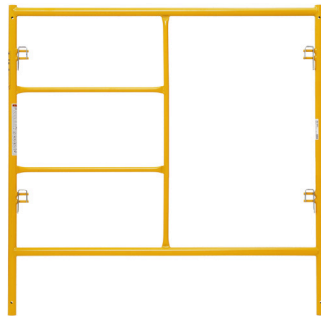

Description	Part Number	Weight
5' W x 2' H Frame	_004-1252_	23
5' W x 3' H Frame	_004-0253_	27
5' W x 4' H Frame	_004-0254_	33
5' W x 5' H Frame	_004-0255_	39
5' W x 6' H Frame	_004-0256_	45
5' W x 6' 4" H Frame	_004-0257_	54
5' W x 6' 6" H Frame	_004-0258_	47

Other step frames available - Contact factory

## OPEN END FRAMES - specify tube size, lock type, and cane type

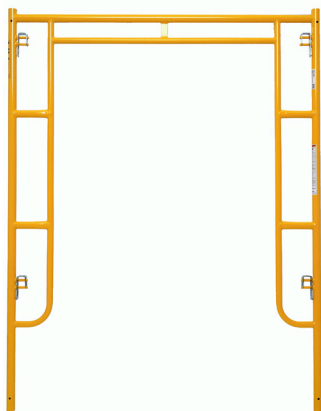

Description	Part Number	Weight
3' W x 6' 4" H Frame	7004-__37_	43
3' W x 6' 6" H Frame	_004-__38_	40
4' W x 6' 4" H Frame	7004-__47_	51
4' W x 6' 6" H Frame	_004-__48_	46
5' W X 6' 4" H Frame	7004-__57_	54
5' W x 6' 6" H Frame	_004-__58_	50

Other open end frames available - Contact factory

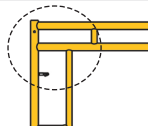

Closed Cane  
05

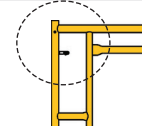

Open Cane  
25

## DOUBLE STEP FRAMES - specify tube size and lock type

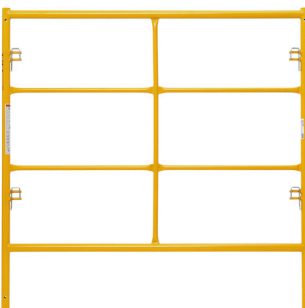

Description	Part Number	Weight
5' W x 3' H Frame	_004-0353_	27
5' W x 4' H Frame	_004-0354_	35
5' W x 4' 6" H Frame	_004-0359_	41
5' W x 5' H Frame	_004-0355_	43
5' W x 6' H Frame	_004-0356_	51
5' W x 6' 4" H Frame	_004-0357_	54
5' W x 6' 6" H Frame	_004-0358_	53

Other double step frames available - Contact Factory

# Frames (cont.) / Rolling Tower Packages

## LADDER FRAMES - specify tube size and lock type



Description	Part Number	Weight	Description	Part Number	Weight
28" W x 3' H Frame*	_004-1423_	16	3' W x 5' H Frame	_004-1435_	29.5
28" W x 4' H Frame*	_004-1424_	21	3' W x 6' H Frame	_004-1436_	36
28" W x 5' H Frame*	_004-1425_	26	4' W x 3' H Frame	_004-1443_	22.5
28" W x 6' H Frame*	_004-1426_	31	4' W x 4' H Frame	_004-1444_	29
3' W x 3' H Frame	_004-1433_	18.5	4' W x 5' H Frame	_004-1445_	36
3' W x 4' H Frame	_004-1434_	24	4' W x 6' H Frame	_004-1446_	43

\*Exact overall width measurement is needed when ordering 28" wide frames

Other ladder frames available - Contact factory

## OPEN LADDER FRAMES - specify tube size and lock type (12" Rung Spacing)

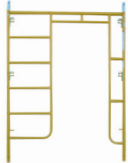

Description	Part Number	Weight
5' W x 6' 4" H Frame	7004-4057_	56
5' W x 6' 6" H Frame	_004-4058_	57

Other open ladder frames available - Contact factory

## CENTER ACCESS FRAMES - specify tube size and lock type (12" Rung Spacing)

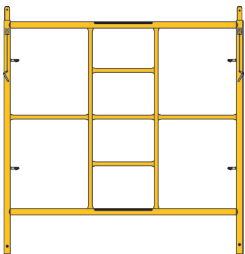

Description	Part Number	Weight
5' W x 2' H Frame	_004-1952_	24
5' W x 3' H Frame	_004-1953_	28
5' W x 4' H Frame	_004-1954_	34
5' W x 5' H Frame	_004-1955_	39
5' W x 6' H Frame	_004-1956_	55

Other center access frames available - Contact factory

## SIDEWALK FRAMES - specify tube size and lock type

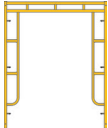

Description	Part Number	Weight
6' W x 7' 8" H Frame furnished with Hex Lock Nut	_004-6000_	65

Other sidewalk frames available - Contact factory

## PEDESTAL SCAFFOLD FRAME - specify tube size and lock type



Description	Part Number	Weight
Pedestal Scaffold Frame	0006-54	37
Replacement Frame Only	0006-54-F	17
Replacement Leg Only	0006-54-L	10

## ROLLING TOWER PACKAGES - 5' Wide - specify tube size



Part Number (5, 6, 7)	Range	Work Ht.	Weight
<b>7' Lengths</b>			
_004C-7X10RT	2' - 11'	17'	462
_004C-7X15RT	2' - 16'	22'	664
_004C-7X20RT	2' - 21'	27'	775
_004C-7X25RT	2' - 26'	32'	881
<b>10' Lengths</b>			
_004C-10X11RT	2' - 11'	17'	542
_004C-10X16RTOR	2' - 16'	22'	756
_004C-10X21RTOR	2' - 21'	27'	876
_004C-10X26RTOR	2' - 26'	32'	946
_004C-10X31RTOR	2' - 31'	37'	1105
_004C-10X36RTOR	2' - 36'	42'	1220



# Pin Options / Fastening Pins / Braces

## INSERT PINS - specify tube size

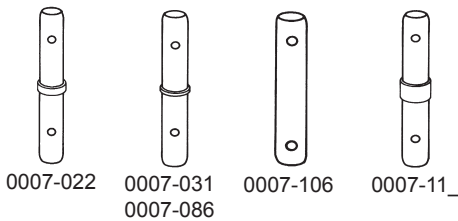

Part Number (5, 6, 7)	Description	Weight
0007-022	9" Pin with 1/2" collar (fits tube size 6)	90/ct
0007-031	9" Pin with 1/8" collar (fits tube size 6)	90/ct
0007-086	9" Pin with 1/8" collar (fits tube size 5)	70/ct
0007-106	7" Pin without collar (fits tube size 6)	60/ct
0007-11_	9" Pin with 1" collar (fits tube size 5, 6, 7)	90/ct
0007-134	9" Pin with special collar (fits tube sizes 6, 7)	100/ct

## INSERT ATTACHMENT OPTIONS - specify tube size



Part Number (5, 6, 7)	Description	Weight
0200-001	Rivet and cotter attachment	.1
0200-002	Spring rivet attachment	.1
0200-003_	Drive pin attachment	.1

## FASTENING PINS



Part Number	Description	Weight
0066-0046-50	2" Gravity pig tail pin	9.1
0068-012-50	2" Hinge pin	5
0068-018-50	3" Hinge pin	6.6
0068-023-50	Spring rivet	2
0068-037-50	2" Rivet pin with cotter	4
0068-038-50	3" Rivet pin with cotter	5
0068-061-50	2" Snap pin	6
0068-100-50	2 1/2" Snap pin	8
0068-102-50	4 1/2" Snap pin	10
0090-0494-50	Drive pin for permanent attachment (tube size 7)	2
0090-0496-50	Drive pin for permanent attachment (tube size 6)	2

## CAT-A-CORNER SQUARING BRACES - specify tube size



Part Number (5, 6, 7)	Description	Weight
0019-4_-507	Squaring brace for a 5' W x 7' L tower	16
0019-4_-508	Squaring brace for a 5' W x 8' L tower	18
0019-4_-510	Squaring brace for a 5' W x 10' L tower	20

Other Cat-A-Corner squaring braces available. Contact Factory

## GALVANIZED DIAGONAL BRACES - specify end type and lock spacing

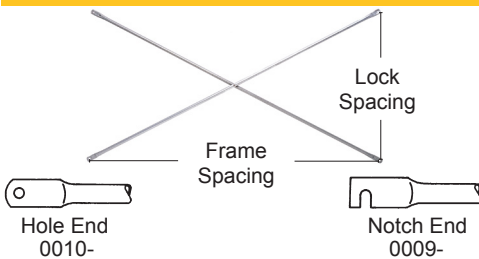

Description	Weight
5' Brace	9
7' Brace	12
8' Brace	14
10' Brace	17

Other diagonal braces available. Contact Factory

## DOUBLE HOLE GALVANIZED DIAGONAL BRACES - 36" & 48" lock spacing

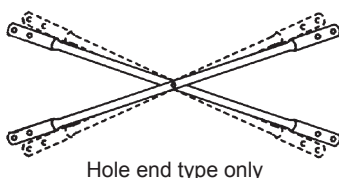

Part Number	Description	Weight
0010-34-07	7' Spacing brace	12
0010-34-08	8' Spacing brace	14
0010-34-10	10' Spacing brace	17

Other diagonal braces available. Contact Factory

# Braces / Leveling Jacks / Base Plates / Guard Rails

## ARM BRACES - 27 3/4" lock spacing

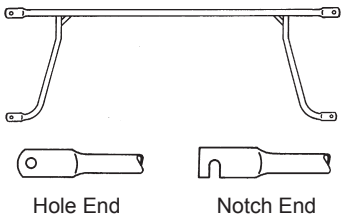

Part Number	Description	Weight
0013-03-07	7' spacing brace - notch end	15
0013-03-10	10' spacing brace - notch end	19
0013-15-07	7' spacing brace - hole end	15
0013-15-08	8' spacing brace - hole end	16
0013-15-10	10' spacing brace - hole end	19

Other arm braces available. Contact Factory

## LEVELING JACKS - specify tube size



Part Number (5, 6, 7)	Description	Weight
0032-08_*	Rigid jack 24" stem with 15" adjustment	10.2
0032-085PL	Plated rigid jack 24" stem with 15" adjustment	10.5
0032-086PL	Plated rigid jack 24" stem with 15" adjustment	12.5
0032-09_*	Swivel jack 24" stem with 15" adjustment	12
0034-08_	Extension 15" adjustment with retainer kit	11.5
0069-0071	Leveling stem retainer	1

Other leveling jacks available. Contact Factory \*To fit tube sizes 6 and 7, select 6 in the part number

## BASE PLATES / RUBBER PAD - specify tube size

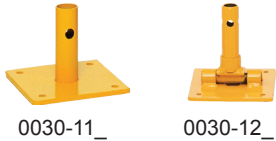

Part Number (5, 6, 7)	Description	Weight
0030-11_	Rigid base plate - 4" stem	3
0030-12_	Swivel base plate - 4" stem	4
0082-0740	Rubber pad for base plate	.5

## CASTERS - specify tube size



Part Number (5, 6, 7)	Description	Weight
0026-7_2	8" wheel size - 4" stem size - 500 lb capacity (cast iron)	13
0026-9_2	8" wheel size - 4" stem size - 500 lb capacity (plastic)	9

## GUARD RAIL POSTS - specify tube size

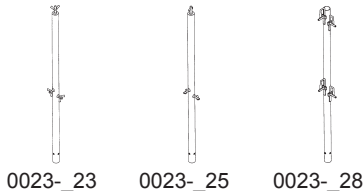

Part Number (5, 6, 7)	Description	Weight
0023-_18	Guard rail post - U-lock	5.5
0023-_23	Corner guard rail post - B-lock	5.7
0023-_25	Corner guard rail post - F-lock	5.5
0023-_28	Corner guard rail post - U-lock	5.5

## GUARD RAILS - GALVANIZED



Part Number	Description	Weight
0022-02-28	End rail - 28" spacing	3
0022-01-03	End rail - 36" spacing	3
0022-02-04	End rail - 46 1/2" spacing (fits tube size 5)	3
0022-01-04	End rail - 48" spacing (fits tube sizes 6, 7)	3
0022-02-05	End rail - 58 1/2" spacing (fits tube size 5)	4
0022-01-05	End rail - 60" spacing (fits tube sizes 6, 7)	4
0022-01-07	Side rail - 7' spacing	5.25
0022-01-08	Side rail - 8' spacing	6.5
0022-25-10	Side rail - 10' spacing	8

Other side guard rail sizes available. Contact factory

# Guard Rails / Toeboards / Easi-Guard System / Walkboards

## INTERMEDIATE GUARD RAIL FOR OPEN END TYPE FRAMES

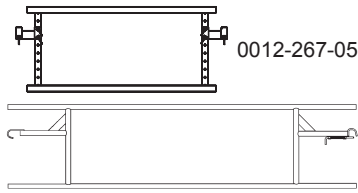

Part Number	Description	Weight
0012-263-07	7' Intermediate side guard rail panel	21
0012-263-08	8' Intermediate side guard rail panel	23
0012-263-10	10' Intermediate side guard rail panel	27
0012-267-05	5' W Intermediate end guard rail panel	21.5
Other intermediate guard rail panel sizes available		

## 6" STEEL TOEBOARDS



Part Number	Description	Weight
0012-016-03	End toeboard 26 5/8" (fits tube sizes 5,6)	4
0012-016-04	End toeboard 26 5/16" (fits tube size 7)	4
0012-016-05	End toeboard 36" (fits tube sizes 5, 6, 7)	5
0012-016-06	End toeboard 46 1/2" (fits tube size 5)	6
0012-016-07	End toeboard 48" (fits tube sizes 6, 7)	6
0012-016-08	End toeboard 58 1/2" (fits tube size 5)	7
0012-016-09	End toeboard 60" (fits tube sizes 6, 7)	7.8
0012-016-12	Side toeboard 7' (fits tube sizes 5, 6, 7)	9
0012-016-14	Side toeboard 8' (fits tube sizes 5, 6, 7)	10
0012-016-18	Side toeboard 10' fits tube sizes (5, 6, 7)	12

## TOEBOARD CLIPS

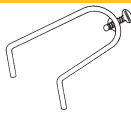

Part Number	Description	Weight
0063-0199	Toeboard clip	.5
0063-0203	Corner toeboard bracket	.5

## EASI-GUARD SYSTEM - specify tube size

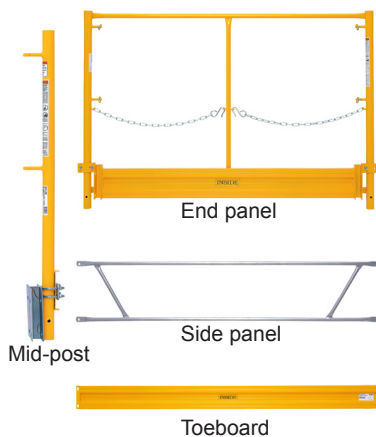

Part Number (5, 6, 7)	Description	Weight
0012-202-07	Side toeboard 7' steel	8
0012-202-08	Side toeboard 8' steel	10
0012-202-10	Side toeboard 10' steel	14.5
0012-209-07	Side panel 7'	12
0012-209-08	Side panel 8'	14
0012-210-10	Side panel 10'	17
0012-22_-28	End panel 28" with toeboard	14
0012-22_-03	End panel 36" with toeboard	17
0012-22_-04	End panel 48" with toeboard	21
0012-22_-05	End panel 60" with toeboard	34
0012-23_	Mid-post	9

## SWING GATE

Part Number	Description	Weight
0012-368	Swing gate for 5' W open end frames	22
0253-35	Swing gate - Adjustable 3' - 5'	33

## X-PANDED STEEL WALKBOARD - STEEL FRAME WITH EXPANDED STEEL DECK

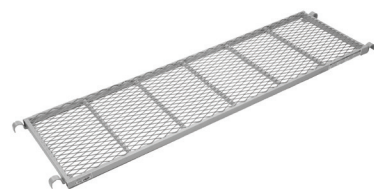

Part Number	Description	Weight
0044-205	19" W x 7' L - 75 psf capacity	45
0044-225	24" W x 7' L - 75 psf capacity	52
0044-227	24" W x 8' L - 75 psf capacity	58
0044-235	28" W x 7' L - 75 psf capacity	56
0044-237	28" W x 8' L - 75 psf capacity	64
0044-245	32" W x 7' L - 75 psf capacity	62
Other side guard rail sizes available. Contact factory		

# Walkboards

## TUF-N-LITE WALKBOARD ALUMINUM FRAME WITH PLYWOOD DECK

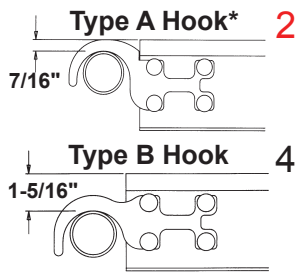

Type A part numbers listed. For Type B replace red 2 with a 4 in the part number

Part Number	Description	Weight
0054-216	19" W x 7' L - 75 psf capacity	32
0054-220	19" W x 10' L - 75 psf capacity	46.5
0054-220-50	19" W x 10' L - 50 psf capacity	40
0054-226	22" W x 7' L - 75 psf capacity	35
0054-230	22" W x 10' L - 50 psf capacity	44.5
0054-236	24" W x 7' L - 75 psf capacity	37
0054-240	24" W x 10' L - 50 psf capacity	50
0054-246	28" W x 7' L - 75 psf capacity	39
0054-250	28" W x 10' L - 50 psf capacity	54
0054-256	32" W x 7' L - 50 psf capacity	47
Other Tuf-N-Lite walkboard sizes available. Contact factory.		

## TUF-N-LITE WALKBOARD REPLACEMENT PARTS

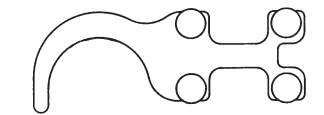

Aluminum hook replacement kit



Plywood deck replacement



Aluminum cross member

Part Number	Description	Part Number	Description
0054-007-07	7' Aluminum rail 4 mem / punch	0090-0545	1/4 - 20 x 1S / tap screw
0054-002-07	7' Aluminum rail 3 mem / punch	0090-0987	3/16 drive rivet
0054-007-08	8' Aluminum rail 4 mem / punch	0191-0019	Plywood for 0054-216
0054-002-08	8' Aluminum rail 3 mem / punch	0191-0022	Plywood for 0054-220
0054-009-10	10' Aluminum rail 4 mem / punch	0191-0049	Plywood for 0054-248
0054-102	Lock - swivel assembly, heavy duty A	0191-0050	Plywood for 0054-250
0054-101	Lock - swivel assembly, heavy duty B	0054-080	Conversion kit 2-bolt to 4 bolt
0054-130	Aluminum hook type A replacement kit		
0054-131	Aluminum hook type B replacement kit		
0054-018-05	Aluminum cross member for 19" walkboard		
0054-018-08	Aluminum cross member for 28" walkboard		
0054-018-09	Aluminum cross member for 32" walkboard		
Other Tuf-N-Lite replacement parts available. Contact factory.			

## X-TRU-LITE WALKBOARD 7100 SERIES - ALUMINUM FRAME AND DECK

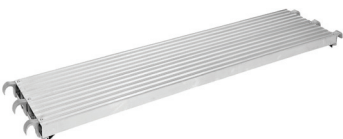

Part Number	Description	Weight
0055-216	19" W x 7' L - 75 psf capacity	32
0055-220	19" W x 10' L - 50 psf capacity	40
Other X-Tru-Lite walkboard sizes available. Contact factory.		

## X-TRU-LITE WALKBOARD REPLACEMENT PARTS

Part Number	Description	Weight
0055-216-3	End Support / 19" X-Tru-Lite	1
0082-0553	Aluminum hook repair kit - 1 hole	4

## OUTRIGGER - specify tube size (5, 6, 7)



Part Number (5, 6, 7)	Description	Weight
0048-2_	30" W outrigger	14



# Brackets / Hoist Arm / Outrigger / Putlogs

## SIDE AND END BRACKETS - specify tube size

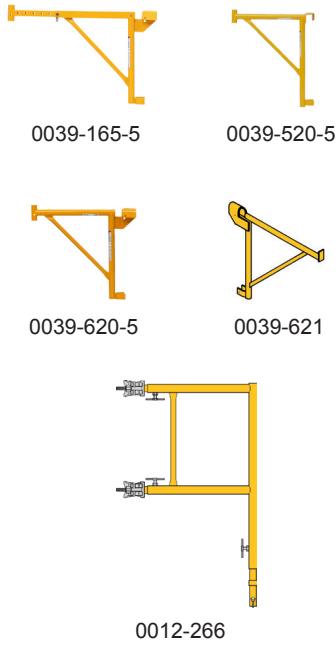

Part Number	Description	Capacity	Weight
<b>SIDE BRACKETS</b>			
0039-620-__	20" Saddle hanger with tube end	500 lb	9
0039-624-__	24" Saddle hanger with tube end	500 lb	10
0039-630-__	30" Saddle hanger with tube end	500 lb	13
0039-165-__	20" - 30" Adjustable saddle hanger with tube end	500 lb	14
0039-124	12" Saddle hanger with plate end	500 lb	6
0039-621	21" Saddle hanger with plate end	500 lb	9
0039-720-__	20" Angle iron hanger - side hang-on with tube end	500 lb	9
0039-724-__	24" Angle iron hanger - side hang-on with tube end	500 lb	11.5
0039-730-__	30" Angle iron hanger - side hang-on with tube end	500 lb	13
0039-171-__	20" - 30" Adjustable angle iron hanger with tube end	500 lb	14
<b>END BRACKETS</b>			
0039-520-__	20" End and side hang-on with tube end	500 lb	10.5
0039-524-__	24" End and side hang-on with tube end	500 lb	13
0039-530-__	30" End and side hang-on with tube end	500 lb	14
<b>END GUARD RAIL FOR SIDE BRACKET</b>			
0012-266	End guard rail for 20" to 30" side bracket		19

## HOIST ARM - WELL WHEEL - TIE BRACE

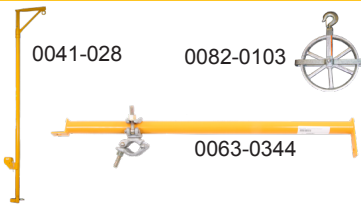

Part Number	Description	Weight
0041-028	Swivel head hoist arm	29
0082-0103	10" Well wheel	9.3
0063-0344	Scaffold tie brace	11

## PUTLOGS

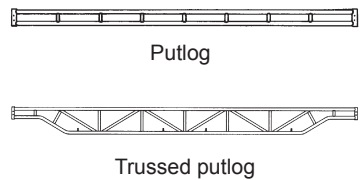

Part Number	Description	Weight	Part Number	Description	Weight
0036-178	8' Putlog	24	0036-602	18' Putlog - trussed	79
0036-180	10' Putlog	30	0036-603	20' Putlog - trussed	92
0036-182	12' Putlog	36	0036-604	22' Putlog - trussed	101
0036-600	14' Putlog - trussed	47	0036-605	24' Putlog - trussed	111
0036-601	16' Putlog - trussed	70	0036-606	26' Putlog - trussed	118

Other putlog sizes available. Contact factory.

## PUTLOG ACCESSORIES

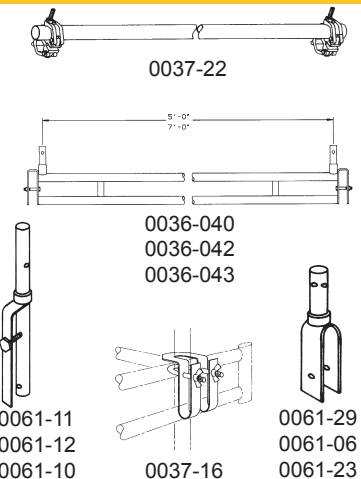

Part Number	Description	Weight
0037-16	Putlog angle hanger	3.5
0061-11	Offset insert saddle (tube size 5)	3
0061-12	Offset insert saddle (tube size 6)	3
0061-10	Offset insert saddle (tube size 7)	3
0061-29	Insert saddle (tube size 5)	3
0061-06	Insert saddle (tube size 6)	3
0061-23	Insert saddle (tube size 7)	3
0037-22	Putlog support 8' L with clamps	20
0036-040	Putlog spreader - 5' frame sp (tube size 6)	24
0036-042	Putlog spreader - 5' frame sp (tube size 5)	14
0036-043	Putlog spreader - 7' frame sp (tube size 5)	24

Other putlog accessories available. Contact factory.

# Clamps / Brackets / Replacement Parts / Stair Tower Components

## DROPPED FORGED CLAMPS

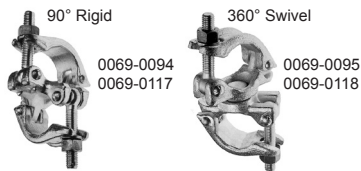

Part Number	Description	Weight
0069-0094	Rigid clamp with "Eye" bolt - fits 1.625", 1.69", 1.9" tube diameter	3
0069-0095	Swivel clamp with "Eye" bolt - fits 1.625", 1.69", 1.9" tube diameter	3
0069-0117	Rigid clamp with "Eye" bolt - fits 1.69" and 1.9" tube diameter	3
0069-0118	Swivel clamp with "Eye" bolt - fits 1.69" and 1.9" tube diameter	3

## BRACKETS AND CLAMPS

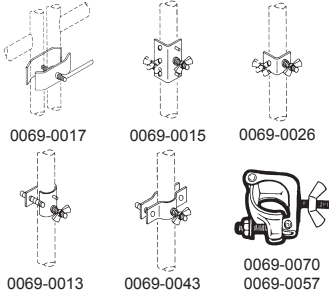

Part Number	Description	Weight
0069-0017	Parallel tube clamp	1.5
0069-0015	Bracket for hole or notched brace	.5
0069-0026	Bracket for hole brace	.5
0069-0013	Clamp for notched brace	1.5
0069-0043	Clamp for hole brace	1.5
0069-0070	B-Lock clamp (tube size 5)	.5
0069-0057	B-Lock clamp (tube size 6, 7)	.5

## REPLACEMENT PARTS

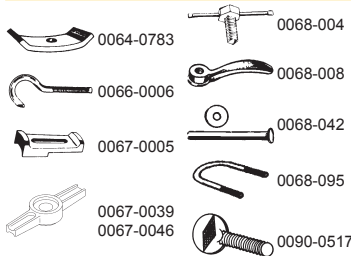

Part Number	Description	Part Number	Description
0064-0783	Half outrigger clamp	0068-008	Lever tail nut 5" L
0066-0006	Putlog clamp hook	0068-042/1	Brace rivet with 3 washers
0067-0005	Gooser brace slide	0068-042/50	Package 50 brace rivets with 150 washers
0067-0039	Leveling nut (1 7/16")	0068-095	U-Bolt only - Putlog angle hanger 0037-16
0067-0046	Leveling nut (1 1/4")	0090-0517	Thumb screw - 3/8" D x 1 1/4" L
0068-004	1/2" set screw		

## BRACE LOCK PARTS



Part Number	Description	Part Number	Description
0068-123A	C-Lock with stud pin	0008-042	F-Lock complete
0068-123	C-Lock stud	0008-048	U-Lock complete
0064-0604	C-Lock slide	0068-009	J-Lock stud 1/2"
0008-022-4/50	C-Lock washer	0066-0044	J-Lock pin 3/8" x 3/4"
0090-0311/50	C-Lock roll pin	0068-013	J-Lock wing nut 1/2"
0008-044	T-Lock complete		

## TUF-N-LITE HINGED LADDER BOARD - ALUMINUM FRAME, PLYWOOD DECK, ATTACHED LADDER



Part Number	Description	Weight
0054-125-07	28" W x 7' L - 75 psf capacity	69
0054-125-08	28" W x 8' L - 50 psf capacity	75
0054-125-10	28" W x 10' L - 50 psf capacity	81

## STAIR TOWER COMPONENTS

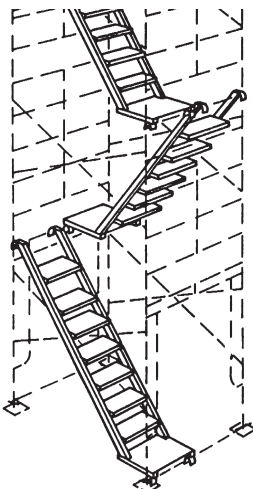

Part Number	Description	Part Number	Description
0042-019	Stair platform rest (tube size 5)	0043-185	Outside handrail (top section)
0042-027	Stair platform rest (tube size 6)	0042-175	Inside handrail (top section)
0042-035	Stair platform rest (tube size 7)	0042-617	24" W stair section 6' 5"
0042-047	Open frame safety guard	0042-618	24" W stair section 6' 6"
0042-094	Outside handrail	0042-619	24" W stair section 6' 7"
0042-093	Inside handrail		
0044-052	Intermediate catwalk 28" W x 7' L with guard rail		
0044-054	Hinged platform 28" W x 7' L expanded steel		
0044-235	28" W x 7' L expanded steel catwalk - 75 psf capacity		

BilJax offers a heavy duty stair tower for worker access to buildings, bridges, observation towers, or renovation done inside or outside. The stairs can also be used for access in a scaffold set-up.

# Access Ladder / Climbing Ladder

## ACCESS LADDER SYSTEM (see below image)

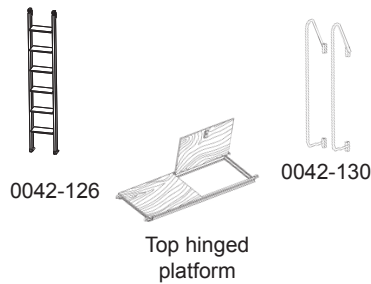

Part Number	Description	Weight
0042-126	6' Access ladder (use with 6' 6" H frame)	37
0042-130	6' Handrails (pair)	23/pr
0042-129	Platform rest (tube size 5; 2 required at 1st tier only)	7.5
0042-128	Platform rest (tube size 6, 7; 2 required at 1st tier only)	8
0054-346	Top hinged platform 28" x 7'	43
0054-348	Top hinged platform 28" x 8'	49
0054-350	Top hinged platform 28" x 10'	55

## CLIMBING LADDER - TUBULAR TYPE (see below image)

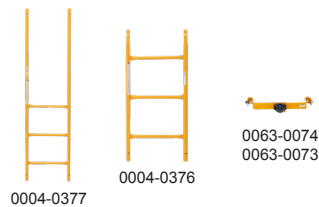

Part Number	Description	Weight
0004-0375	6' Ladder section	19
0004-0376	3' Ladder section	17.5
0004-0377	6' Top section	9.2
0063-0074	Support bracket (tube size 5)	5.5
0063-0073	Support bracket (tube size 6, 7)	5.5

## CANOPY TOP / WEATHER PROTECTION CLIP (see below image)

Part Number	Description	Weight
0071-021	Canopy top with adjustable extension - 5' W x 1' H (tube size 6)	27
0071-022	Canopy top with adjustable extension - 5' W x 1' H (tube size 7)	27
0071-024	Canopy top with adjustable extension - 5' W x 1' H (tube size 5)	27
0082-0228	Weather protection clips 8" L (qty. 100) - Fits 1.5" tube diameter	16
0082-0874	Weather protection clips 11" L (qty. 100) - Fits 1.69" and 1.9" tube diameter	20

## ADDITIONAL ILLUSTRATIONS

ACCESS LADDER SYSTEM

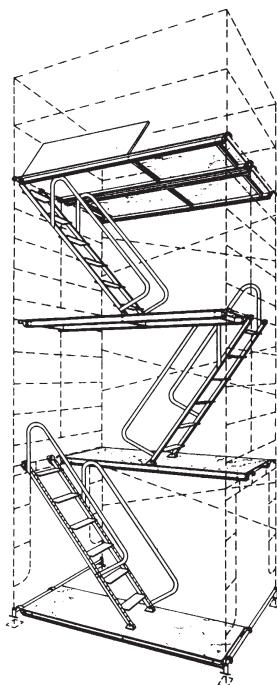

CLIMBING LADDER  
TUBULAR TYPE

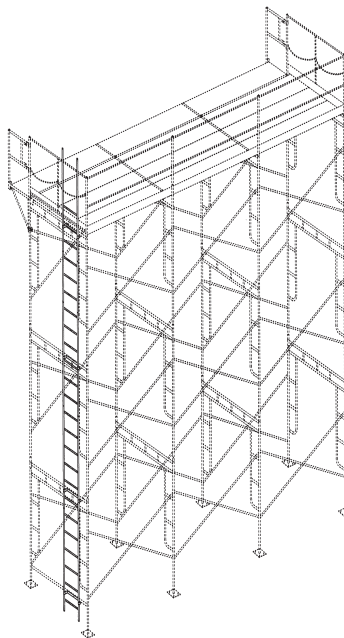

CANOPY TOP  
WEATHER PROTECTION CLIP

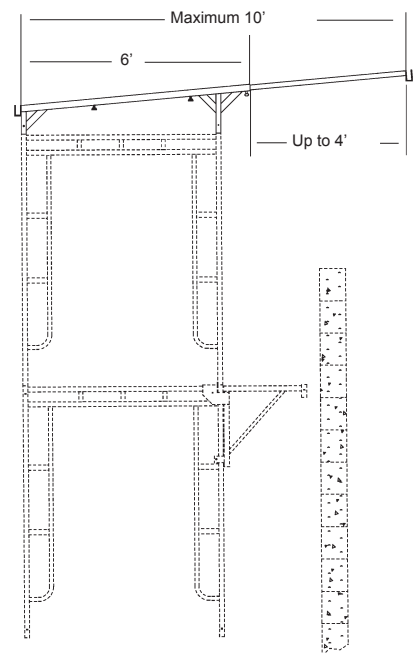

# Pro-Jax Scaffold Packages / Guard Rail

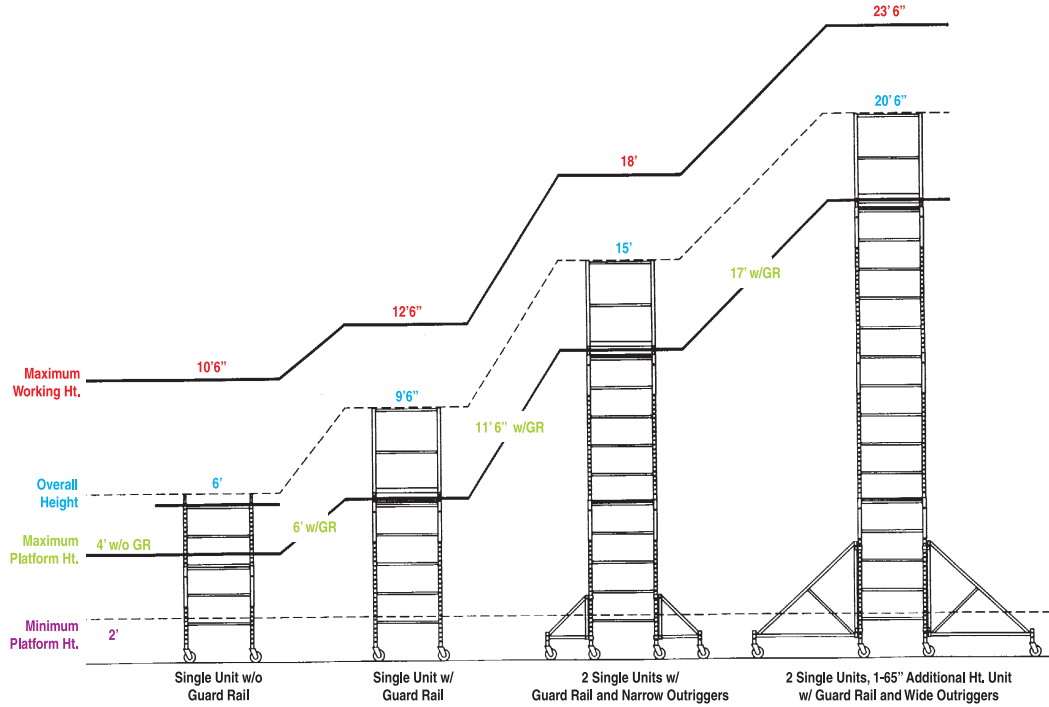

## PRO-JAX UTILITY SCAFFOLD PACKAGES WITH PLYWOOD DECK WALKBOARDS



Part Number	Description		Includes		Weight
	Length	Platform Ht Range	Guard Rails	Outriggers	
0127-006-0	6'	2' - 4'	No	No	147
0127-006-1	6'	2' - 6'	Yes	No	240
0127-006-2	6'	2' - 11.5'	Yes	Yes	430
0127-006-3	6'	2' - 17'	Yes	Yes	538
0127-008-0	8'	2' - 4'	No	No	173
0127-008-1	8'	2' - 6'	Yes	No	279
0127-008-2	8'	2' - 11.5'	Yes	Yes	490
0127-008-3	8'	2' - 17'	Yes	Yes	609
0127-010-0	10'	2' - 4'	No	No	200
0127-010-1	10'	2' - 6'	Yes	No	316
0127-010-2	10'	2' - 11.5'	Yes	Yes	525
0127-010-3	10'	2' - 17'	Yes	Yes	645

## PRO-JAX UTILITY SCAFFOLD ADDITIONAL HEIGHT PACKAGES

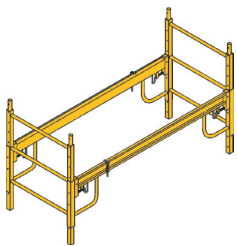

Part Number	Description	Weight
0127-007-3	6' L x 39" H unit	75
0127-007-5	6' L x 65" H unit	95
0127-009-3	8' L x 39" H unit	93
0127-009-5	8' L x 65" H unit	103
0127-011-3	10' L x 39" H unit	97
0127-011-5	10' L x 65" H unit	123

## PRO-JAX GUARD RAIL PACKAGES, OUTRIGGER PACKAGES, AND LEVELING EXTENSION



Part Number	Description	Weight
0127-149-06	6' Complete guard rail package (2 pieces)	81.5
0127-149-08	8' Complete guard rail package (2 pieces)	98
0127-149-10	10' Complete guard rail package (2 pieces)	115
0127-150-18	18" W outrigger package (4 pieces)	39
0127-150-24	24" W outrigger package (4 pieces)	44
0127-138	Leveling extension	



# Pro-Jax Replacement Parts & Components / Handy Roll

## PRO-JAX REPLACEMENT PARTS

Part Number	Description	Weight
0063-0377	L-Pin replacement kit for platform arm brace (For Multi Purpose Unit)	.25
0063-0418	Wind latch replacement kit	.25
0063-0605	Saf-T-Lok replacement kit (For Pro-Jax Unit)	.40

## PRO-JAX COMPONENTS

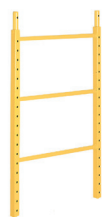

0127-102



0127-101



0127-108-06

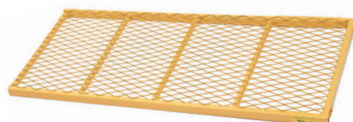

0127-113



0127-149-06



0127-163-06

Part Number	Description	Weight
0127-102	39" H ladder frame	15
0127-101	65" H ladder frame	25
0127-147	Base extension unit	29
0127-163-06	6' Platform arm brace	21
0127-163-08	8' Platform arm brace	26
0127-163-10	10' Platform arm brace	32
0127-108-06	6' Plywood deck	29
0127-108-08	8' Plywood deck	40
0127-108-10	10' Plywood deck	52
0127-141-06	6' Top hinged plywood deck	47
0127-141-08	8' Top hinged plywood deck	60
0127-141-10	10' Top hinged plywood deck	73
0127-113	6' Expanded metal deck	36
0127-114	8' Expanded metal deck	48
0127-115	10' Expanded metal deck	60
0127-106-06	6' Combination guard panel	35.5
0127-106-08	8' Combination guard panel	42
0127-106-10	10' Combination guard panel	48
0127-105-18	18" W outrigger	8
0127-105-24	24" W outrigger	11
0127-118	48" W outrigger	26
0127-136-06	6' Intermediate guard rail	20
0127-136-08	8' Intermediate guard rail	24
0127-136-10	10' Intermediate guard rail	28
0127-138	Adjustable leg with rubber pad	3
0026-835	5" Caster - 250 lb capacity with 2" snap pin (trailing edge brake lock)	4.75
0026-952	8" Caster - 500 lb capacity with 2" snap pin - P5	10



0127-105-18



0026-835



0026-952

## HANDY ROLL SCAFFOLDING 4-CASTER UNITS



Part Number	Description	Weight
0063-0435-34	3' Handy roll scaffold 4-caster unit with steel platforms - 24" W x 48" L x 39" H	82
0063-0435-44	4' Handy roll scaffold 4-caster unit with steel platforms - 24" W x 48" L x 51" H	87
0063-0435-54	5' Handy roll scaffold 4-caster unit with steel platforms - 27" W x 64" L x 63" H	106

# Drywall Cart / Drywall Lift

## DRYWALL CART

0063-0575-11YE



Part Number	Description	Capacity	Weight
0063-0573-01YE	Model DC 3000 LD, light duty with plastic casters (2 swivel - 2 rigid) - 23" W x 49" L x 47" H	TBD	84
0063-0574-11YE	Model DC 3000 MD, medium duty with steel casters (2 swivel - 2 rigid) - 23" W x 49" L x 47" high	TBD	104
0063-0575-11YE	Model DC 3000 EX, heavy duty with steel casters (2 swivel - 2 rigid) - 28" W x 50" L x 47" H	TBD	137

## DRYWALL LIFT

0063-0580



Part Number	Description	Capacity	Weight
0063-0547	Model DL 100 Steel - 5' to 10' lift adjustment	200	104
0063-0580	Model DL 125 Steel - 5' to 12' lift adjustment	200	125
0063-0595	Model DL 150 Steel - 5' to 15' lift adjustment	160	141

## Scaffold Safety Guidelines - recommended by Scaffolding, Shoring & Forming Institute

It shall be the responsibility of all employers and employees to read and comply with the following common sense guidelines which are designed to promote safety in the erecting and dismantling of scaffolds. These guidelines do not purport to be all-inclusive nor to supplant or replace other additional safety and precautionary measures to cover usual or unusual conditions. Local, State or Federal statute or regulations shall supersede these guidelines if there is a conflict and it is the responsibility of each employee to comply.

### GENERAL GUIDELINES

- I. POST THESE SCAFFOLDING SAFETY GUIDELINES in a conspicuous place and be sure that all persons who erect, dismantle or use scaffolding are aware of them.
- II. FOLLOW ALL STATE, LOCAL AND FEDERAL CODES, ORDINANCES AND REGULATIONS pertaining to scaffolding because they may be more restrictive. For example, height or width requirements may vary.
- III. SURVEY THE JOB SITE—A survey shall be made of the job site for hazards, such as untamped earth fills, ditches, debris, high tension wires, unguarded openings, and other hazardous conditions created by other trades. These conditions shall be corrected or avoided as noted in the following sections.
- IV. INSPECT ALL EQUIPMENT BEFORE USING—Never use any equipment that is damaged or defective in any way.
- V. KEEP ALL EQUIPMENT IN GOOD REPAIR—Avoid using corroded equipment—the strength of corroded equipment is not known.
- VI. INSPECT ERECTED SCAFFOLDS DAILY—or at the beginning of every shift to be sure that they are maintained in safe condition.
- VII. NEVER USE EQUIPMENT FOR PURPOSES OR IN WAYS FOR WHICH IT WAS NOT INTENDED.
- VIII. REPORT ANY UNSAFE CONDITION. NEVER TAKE CHANCES—Do not work on scaffolds if your physical condition is such that you feel dizzy or unsteady in any way.
- IX. WORKING UNDER THE INFLUENCE OF ALCOHOL OR ILLEGAL DRUGS IS STRICTLY PROHIBITED.
- X. CONSULT YOUR SCAFFOLDING SUPPLIER—NEVER TAKE CHANCES—Consult manuals and instructions provided by the supplier; scaffolding is his business.

## GUIDELINES FOR ERECTION AND USE OF SCAFFOLDS

- A. PROVIDE ADEQUATE SILLS for scaffold posts and use base plates.
- B. USE ADJUSTING SCREWS or other approved conditions.
- C. PLUMB AND LEVEL ALL SCAFFOLDS as the erection proceeds. Do not force braces to fit—level the scaffold until proper fit can be made easily.
- D. BRACING. Each frame or panel shall be braced by horizontal bracing, cross bracing, diagonal bracing or any combination thereof for securing vertical members together laterally. All brace connections shall be made secure, in accordance with manufacturers' recommendations.
- E. DO NOT CLIMB CROSS BRACES. Use only an access (climbing) ladder, access steps, frame designed to be climbed or equivalent safe access to scaffold.
- F. TIE RUNNING SCAFFOLD TO WALL or structure when the height exceeds\* four (4) times the minimum scaffold base dimension. The first vertical and longitudinal tie shall be placed at this point. Vertical ties shall be repeated at intervals not greater than 26 feet. Longitudinal ties shall be placed at each end and at intervals not greater than 30 feet. Ties must prevent the scaffold from tipping into or away from the wall or structure.
- G. WHEN SCAFFOLDS ARE TO BE PARTIALLY OR FULLY ENCLOSED, specific precautions must be taken to assure frequency and adequacy of ties attaching the scaffolding to the building due to increased load conditions resulting from effects of wind and weather. The scaffolding components to which the ties are attached must also be checked for additional loads.
- H. WHEN FREE STANDING SCAFFOLD TOWERS exceed\* four times their minimum base dimension vertically, they must be restrained from tipping.
- I. DO NOT ERECT SCAFFOLDS NEAR ELECTRICAL POWER LINES UNLESS PROPER PRECAUTIONS ARE TAKEN. Consult the power service company for advice.
- J. DO NOT USE ladders or makeshift devices on top of scaffolds to increase the height.
- K. DO NOT EXCEED MANUFACTURERS' RECOMMENDED LOAD RATING.
- L. EQUIP AND MAINTAIN ALL PLATFORMS with proper guardrails, midrails, and toeboards along all open sides and ends of scaffold platforms.
- M. ALL BRACKETS shall be seated correctly with side brackets parallel to the frames and end brackets at 90 degrees to the frames. Brackets shall not be bent or twisted from normal position. Brackets (except mobile brackets designed to carry materials) are to be used as work platforms only and shall not be used for storage of material or equipment. When brackets are used, the scaffold shall be tied to the structure or otherwise restrained to prevent tipping.
- N. ALL SCAFFOLDING ACCESSORIES shall be used and installed in accordance with the manufacturers' recommended procedure. Accessories shall not be altered in the field. Scaffolds, frames and their components of various manufacturers shall not be intermixed.
- O. FOR PLANKING, THE FOLLOWING GUIDELINES APPLY:
  1. Use only lumber that is properly inspected and graded as scaffold plank.
  2. Planking shall have at least 12 inches of overlap and extend 6 inches beyond center of support, or, be cleated at both ends to prevent sliding off supports.
  3. Fabricated scaffold planks and platforms, unless created or restrained by hooks, shall extend over their end supports not less than 6 inches nor more than 12 inches.
- P. FOR ROLLING SCAFFOLDS THE FOLLOWING ADDITIONAL GUIDELINES APPLY.
  1. CASTERS WITH PLAIN STEMS shall be attached to the panel or adjustment screw by pins or other suitable means.
  2. DO NOT EXTEND ADJUSTING SCREWS ON ROLLING SCAFFOLDS MORE THAN 12 INCHES.
  3. WHEELS OR CASTERS shall be provided with a locking device and kept locked during erection and dismantling or any time scaffolds are not being moved.
  4. SECURE OR REMOVE ALL MATERIAL AND EQUIPMENT from platform before moving scaffold.
  5. USE HORIZONTAL DIAGONAL BRACING near the bottom and at 20 foot intervals measured from the rolling surface.
  6. DO NOT USE brackets or other platform extensions without consideration of overturning effect.
  7. THE HEIGHT OF A ROLLING SCAFFOLD excluding its uppermost guardrails, must not exceed\* four times its smallest base dimension unless it is stabilized by an engineered counterweight system or some other equivalent means.
  8. CLEAT OR SECURE ALL PLANKS.
  9. DO NOT ATTEMPT TO MOVE A ROLLING SCAFFOLD WITHOUT SUFFICIENT HELP—watch out for holes in floor and overhead obstructions—stabilize against tipping.
  10. DO NOT RIDE ROLLING SCAFFOLDS.
  11. JOINTS shall be restrained from separation.
- Q. FOR "PUTLOGS" AND "TRUSSES" the following additional guidelines apply.
  1. DO NOT CANTILEVER OR EXTEND PUTLOGS/TRUSSES as side brackets without thorough consideration for loads to be applied.
  2. PUTLOGS/TRUSSES SHOULD BE EXTENDED AT LEAST 6 inches beyond point of support.
  3. PLACE RECOMMENDED BRACING BETWEEN PUTLOGS/TRUSSES when the span of putlog/truss is more than 12 feet.
- R. WHEN DISMANTLING SCAFFOLDING THE FOLLOWING ADDITIONAL GUIDELINES APPLY:
  1. CHECK TO SEE IF SCAFFOLDING HAS BEEN STRUCTURALLY ALTERED in any way which would make it unsafe, and if so, reconstruct where necessary before commencing with dismantling procedures.
  2. VISUALLY INSPECT PLANK prior to dismantling to be sure that they are safe to work on.
  3. COMPONENTS SHOULD BE LOWERED as soon as dismantled in safe manner so as to protect personnel below.
  4. DO NOT ACCUMULATE EXCESS COMPONENTS OR EQUIPMENT on the level being dismantled.
  5. DISMANTLED EQUIPMENT should be stockpiled in an orderly manner.
- S. FOLLOW ERECTION PROCEDURES AND USE MANUALS.





# Other Offerings from Haulotte



All images are for illustration only. Haulotte | BilJax reserves the right to modify specifications without notice. Follow all applicable ANSI and OSHA codes/regulations when using this equipment. Do not use in ares where user can come in contact with live power.



# SCAFFOLD FRAME MEASUREMENT CHARTS

These facts are needed whenever you are not sure that the frame is a BilJax brand product. If you do not have previous experience with the frame ordered, or if you do not have the item number, answer the below questions and provide them with your order.

## Step frame

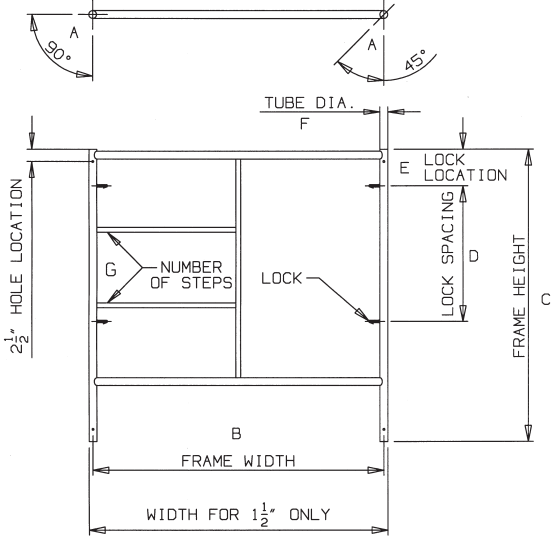

## Open frame

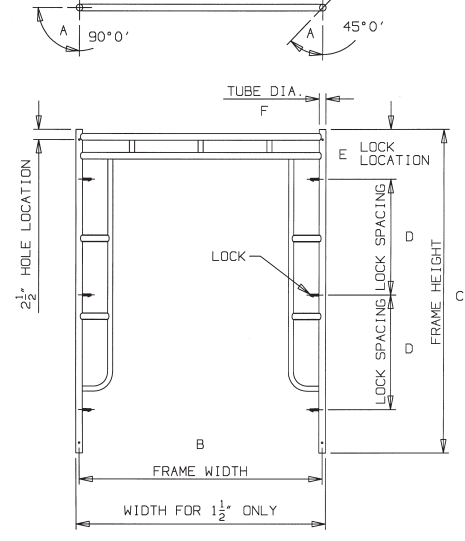

## Center access frame

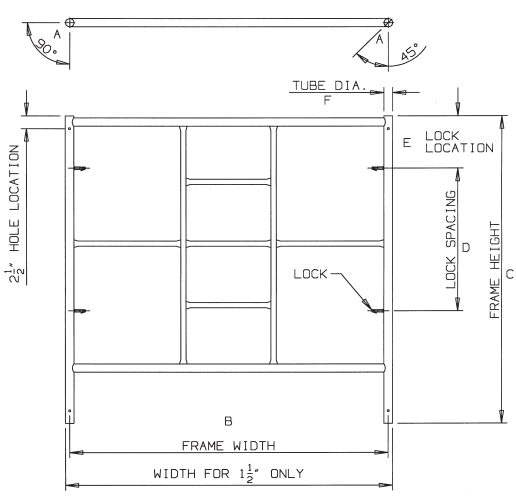

## Ladder frame

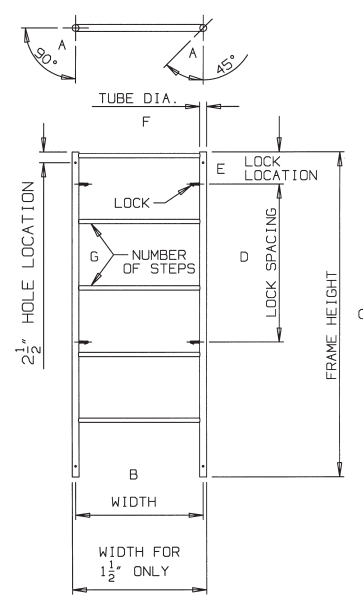

- \_\_\_\_\_ **A. Specify Rotation of Pin Holes**
  1. 90° or 45° top & bottom
  - 90° Standard
- \_\_\_\_\_ **B. Width of Frame Center to Center**
  1. To get this measurement, place tape outside to inside of leg tube.
- \_\_\_\_\_ **C. Frame Height**
  1. Measure overall top to bottom
  2. DO NOT include insert (stacking pin) in measurement
- \_\_\_\_\_ **D. Lock Spacing**
  1. Measure distance from top of top lock pin to top of bottom lock pin
  2. When a lock had two pins, use the lower pin of both locks
- \_\_\_\_\_ **E. Lock Location**
  1. Measure between top of leg and the center of the top lock pin
  2. In case of a two pin lock, use the lower pin
- \_\_\_\_\_ **F. Tube Size of Leg (diameter)**
  1. Measure leg outside to outside
  - 1-1/2", 1-5/8", 1-11/16" standard sizes

