

Holman

Installation Guide 80030

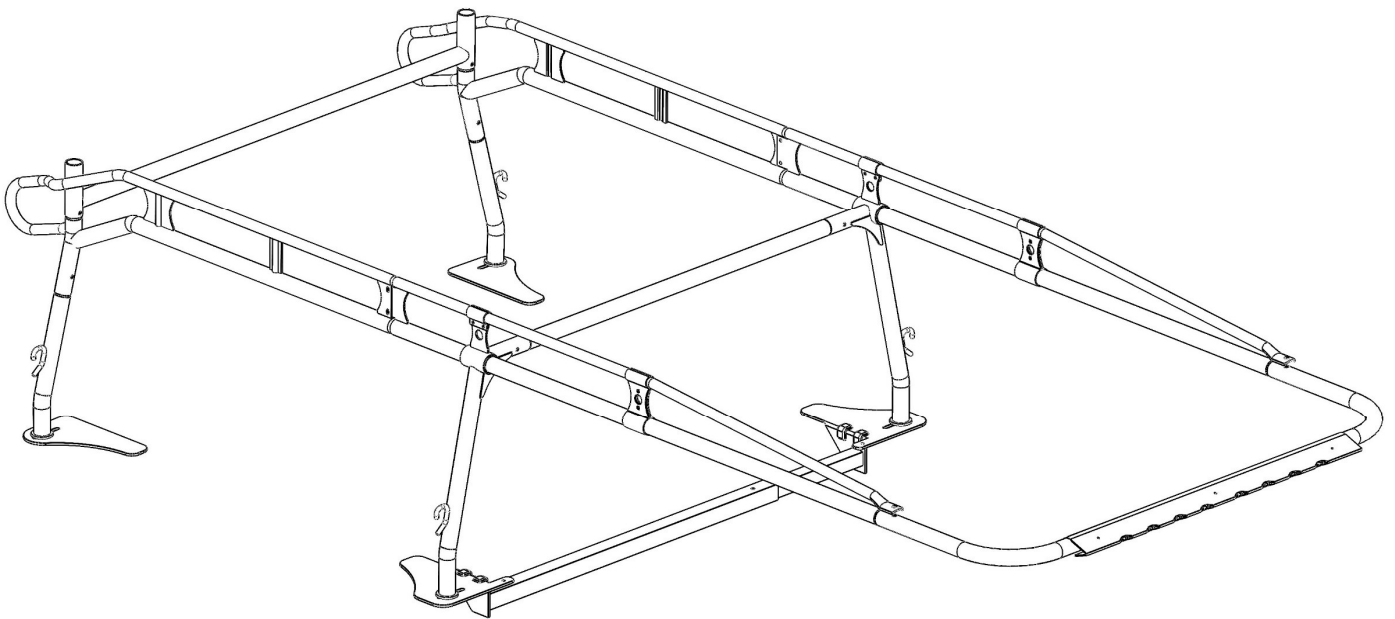

Available at Contractor's Solutions: www.Contractors-Solutions.net

Holman
Rancho Cordova, CA 95742
800-343-7486
InstallationSupport@Holman.com



Before You Begin

- Read all instructions carefully, and follow each step in proper sequence, for ease and speed in assembling your rack.
- PROPER SEALANT APPLICATION IS CRITICAL TO PREVENTING WATER PENETRATION INSIDE THE RACK. Apply a healthy bead of sealant entirely around every swaged joint and every bolt going through tubing. Improper sealing can lead to water penetration and rust on inside surfaces.

DON'T OVERLOAD YOUR VEHICLE!

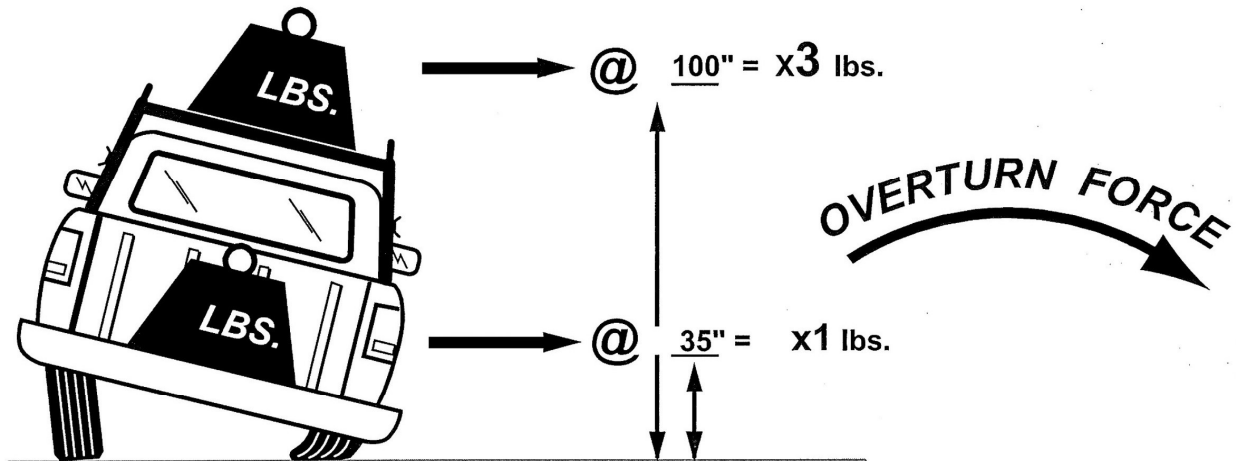

WEIGHT CARRIED ABOVE THE FLOOR OF THE TRUCK BED (E.G. ON AN OVERHEAD TRUCK RACK) WILL SIGNIFICANTLY INCREASE THE VEHICLE'S TENDENCY TO OVERTURN. ALWAYS KEEP HEAVY LOADS EVENLY DISTRIBUTED AND AS LOW AS POSSIBLE. IT IS IMPORTANT TO NOTE THAT THE HOLMAN RACK LOAD BEARING CAPACITY OF 1700 LBS. MAY BE GREATER THAN YOUR TRUCK'S GAWR OR GVWR CAPACITY, AND IS PROBABLY GREATER THAN THE WEIGHT THAT CAN BE SAFELY CARRIED OVERHEAD. RETIGHTEN ALL BOLTS AFTER FIRST USE, PERIODICALLY CHECK BOLTS FOR TIGHTNESS.

For *TECHNICAL SUPPORT* Call:

1.800.343.7486

or email: InstallationSupport@Holman.com

PLEASE READ ALL INSTRUCTIONS AND WARNINGS PRIOR TO ASSEMBLING, INSTALLING, AND USING THIS PRODUCT.

Warning



Always check for wires, fuel tanks and lines, brake lines and other important vehicle functionality items prior to drilling and installing all products.



Too much weight will greatly reduce the stability of your vehicle. Holman makes no representation or warranty as to the amount of weight your vehicle can safely carry. For guidance, we recommend that you consult the vehicle manufacturer.

AT NO TIME SHOULD THE WEIGHT OF THE VEHICLE, RACK, DRIVER, PASSENGERS AND CARGO LOADED ON A HOLMAN RACK EXCEED EITHER THE GROSS VEHICLE WEIGHT RATIO (GVWR) OR THE GROSS AXLE WEIGHT RATIO (GAWR) AS SPECIFIED BY THE VEHICLE MANUFACTURER.



Do not use your rack with the rear cross bar removed. Removal of rear crossbar will affect structural integrity of the rack.



Secure all payloads properly for safe transportation.

Tools Needed

1/2", 9/16", 3/4" Sockets and Wrench	3/4" Box Wrench
3/8" Drill Bit and Drill	1/4", 5/16", 3/8" Allen Wrench

Table of Contents

Before You Begin 1

Tools Needed 2

Parts List..... 3

Hardware (18-31571) 4

Hardware (18-00430) 5

Sealant Application 7

Step 1 – Join Side Channels 7

Step 2 – Install Front Leg Receiver 8

Step 3 – Attach Rear Legs..... 8

Step 4 – Install Center Crossbar..... 8

Step 5 – Install Rear Crossbar..... 9

Step 6 – Install Front Crossbar 9

Step 7 – Attach Wind Deflector..... 9

Step 8 – Attach Mounts 10

Step 9 – Mount Installation Preparation..... 11





Step 10 – Mount Installation 12

Step 11 – Bolt Inner Support Arm..... 13

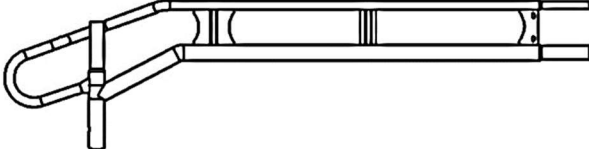
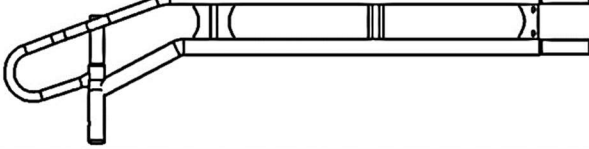

Step 12 – Adjusting Front Legs 14

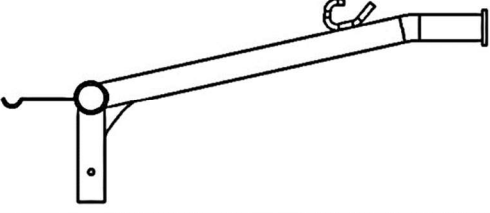
Step 13 – Attach Front Support Upright..... 14

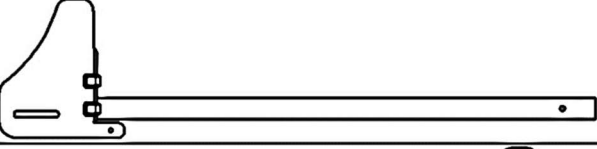
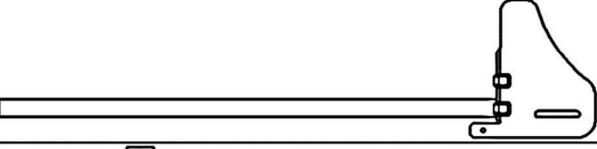
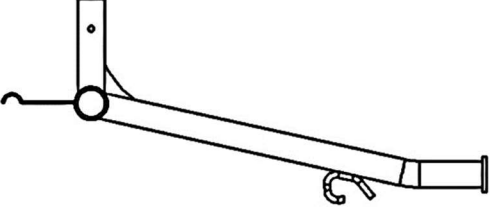
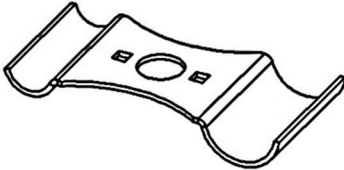
Parts List

NO.	ITEM	PART NUMBER	DESCRIPTION	QTY.
1		101029	REAR SIDE CHANNEL, DS LH	1
2		101030	REAR SIDE CHANNEL, PS RH	1
3		13-01013	FRONT SIDE CHANNEL	2
4		13-01069	FRONT LEG, LD, TRUCK CAP RH PS	1
5		13-01073	REAR LEG	2
6		11-00121	REAR FOOT - LD TRUCK CAP	2
7		13-00845-R2	FRONT FOOT ASSEMBLY, LD TRUCK CAP, RH PS	1
8		13-00846-R2	FRONT FOOT ASSEMBLY, LD TRUCK CAP, LH DS	1
9		13-01068	FRONT LEG, LD, TRUCK CAP LH DS	1
10		11-01013	BRACE PLATE	4

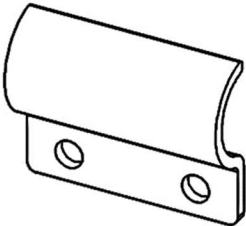
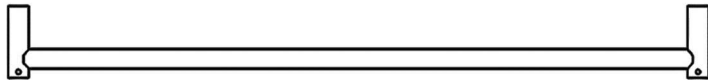

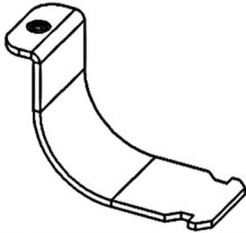
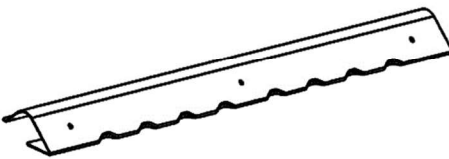

Parts Continued

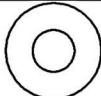
NO.	ITEM	PART NUMBER	DESCRIPTION	QTY.
11		12-00202-1	TOP TUBE HALF CLAMP	2
12		101082	REAR TAKE-OUT BAR ASSEMBLY	1
13		101079	FRONT U-BAR	1
14		101080	FRONT CROSSBAR, LD	1
15		8000S-017	WIND DEFLECTOR CLAMP	3
16		101719	WIND DEFLECTOR	1
17		18-00430	HARDWARE KIT	1
18		18-31571	WIND DEFLECTOR HARDWARE KIT	1



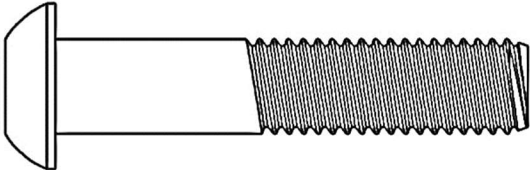
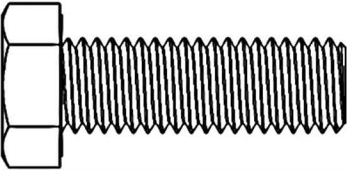

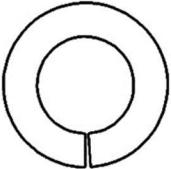
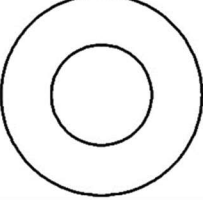
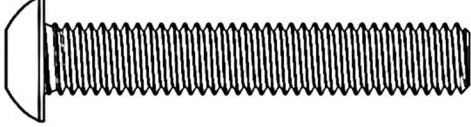
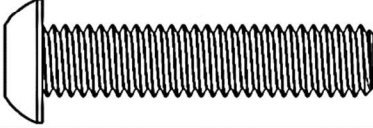
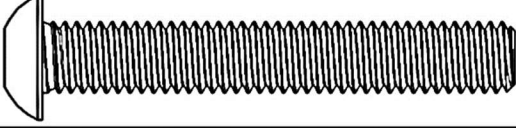
Hardware (18-31571)

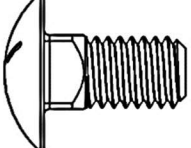
ITEM	HARDWARE TO SCALE	PART NUMBER	DESCRIPTION	QTY.
1		0149489	10-32 X 3/4" PAN HEAD SCREW	3
2		33074	#10 FLAT WASHER	3

Hardware (18-00430)

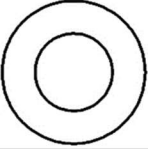
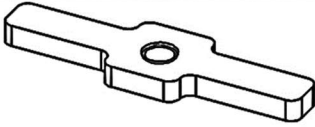
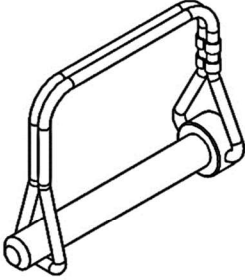
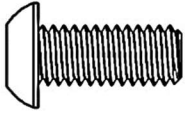
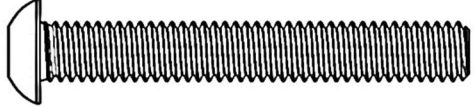
ITEM	HARDWARE TO SCALE	PART NUMBER	DESCRIPTION	QTY.
1			1/2"-13 X 2-1/2" BUTTON HEAD CAP SCREW	2
2		11241229	1/2-13 X 1-1/2" HEX HEAD BOLT	4
3		0169793	1/2-13 NYLON THIN LOCK NUT	2
4		0123524	1/2" LOCKING WASHER	4
5		11541086	1/2" WASHER	6
6		94718	3/8"-16 X 2-1/4" SOCKET CAP SCREW	3
7		94095	3/8"-16 X 1-3/4" BUTTON HEAD CAP SCREW	8
8		94718	3/8"-16 X 2-1/2" SOCKET CAP SCREW	2
9		0169791	3/8"-16 LOCK NUT	11
10		21810	5/16"-18 X 3/4" CARRIAGE BOLT	4

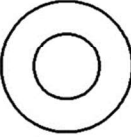
Hardware Continued

ITEM	HARDWARE TO SCALE	PART NUMBER	DESCRIPTION	QTY.
10		1133082	3/8" WASHER	21
11		11-00112	3/8"-16 T-NUT	2
12			3/8" X 2-1/8" WIRE LOCK CLEVIS PIN	2
13		0153308	5/16"-18 X 3/4" BUTTON HEAD SCREW	8
14			5/16-18 X 2-1/4" BUTTON HEAD HEX DRIVE SCREW	2
15			5/16-18 X 3/8" SET SCREW	4
16		0169777	5/16"-18 NYLOC	14
17		33080	5/16" WASHER	14
18			1-5/8" PLASTIC CAP	2
19		-	SELF LEVELING ADHESIVE SEALANT	1

Sealant Application

 **Proper sealant application is critical to preventing water penetration inside the rack AND provides for a stable connection between parts.**

- **Apply a healthy bead of sealant entirely around every swaged joint as shown. Improper sealing can lead to water penetration.**
- Wipe any excess sealant off immediately with a plastic scraper or paper towel. Any smeared sealant can be rubbed off as soon as sealant dries.
- **Maintain this seal throughout the life of your rack.**

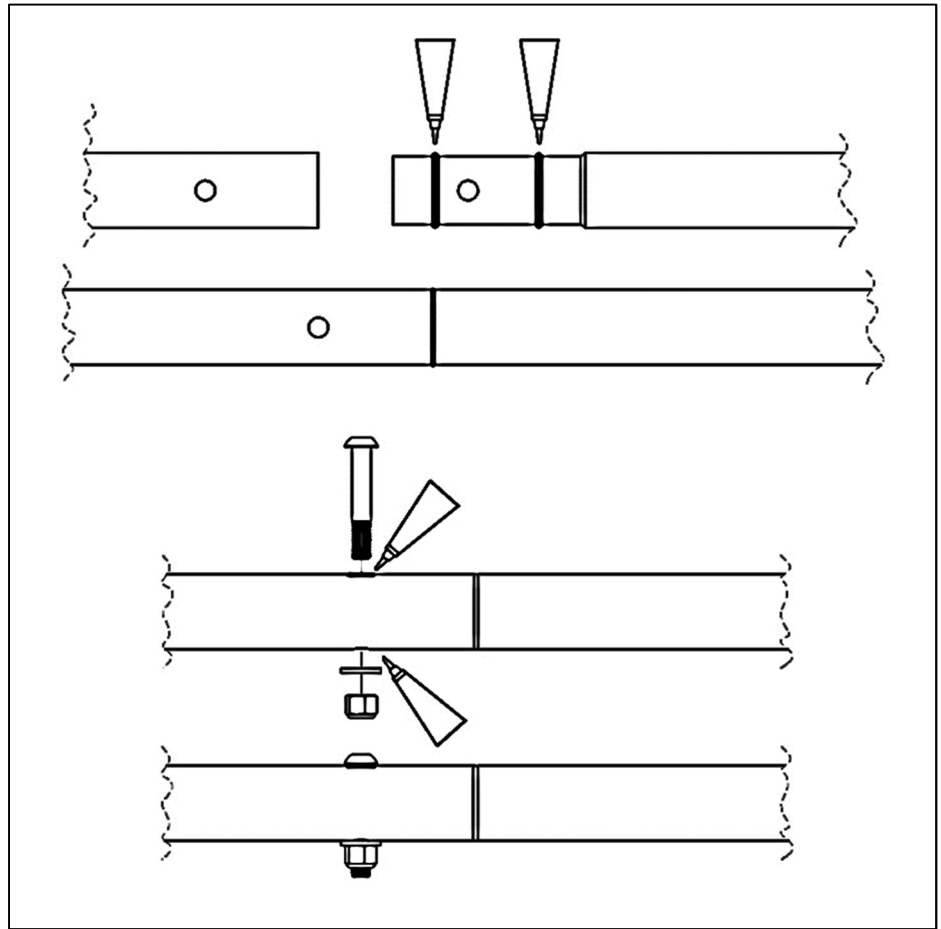

Step 1 – Join Side Channels

- Unpack side channels from box. Lay flattened box on ground and use for scratch protection while building rack.
- Open Assembly Hardware Kit.
- **Be sure you have correct front and rear side channels paired.**
- Apply sealant to both top and bottom swage joints.
- Insert rear side-channel swaged joints into front side-channel tubes until bolt holes in splice plates align.
- Using 5/16" x 3/4" carriage bolts, 5/16" washers, and 5/16" lock nuts, securely fasten channels together.
- Remove excess sealant.
- Repeat process for opposite side.

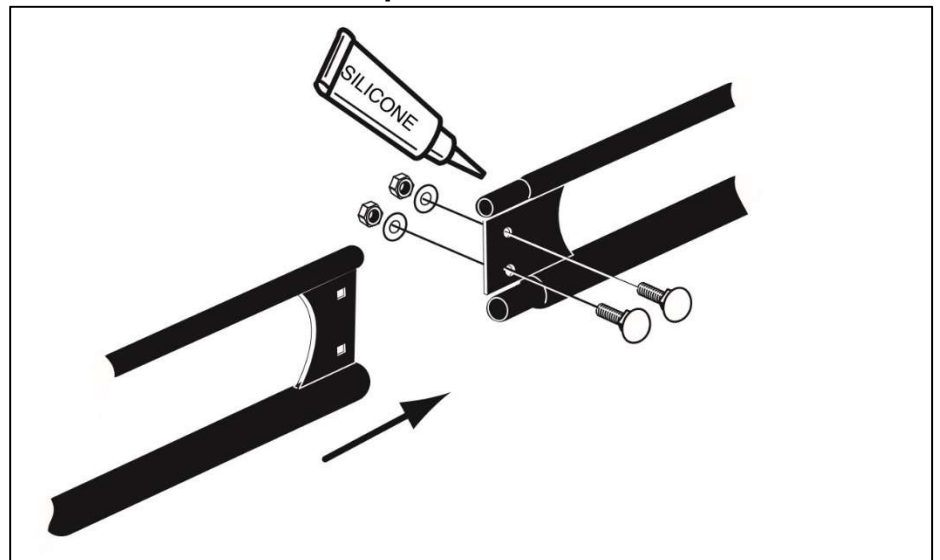

Step 2 – Install Front Leg Receiver

- Slide the FRONT leg onto the front side channel. There is a RIGHT & a LEFT. Match to the correct side channel so that both FRONT & REAR legs angle outward.
- Using 5/16" set screws position distance to match same as above, but do not tighten yet.
- Using two 5/16" X 3/4" button head bolts, two 5/16" washer, and two 5/16" lock nuts loosely attach the top CLAMP.

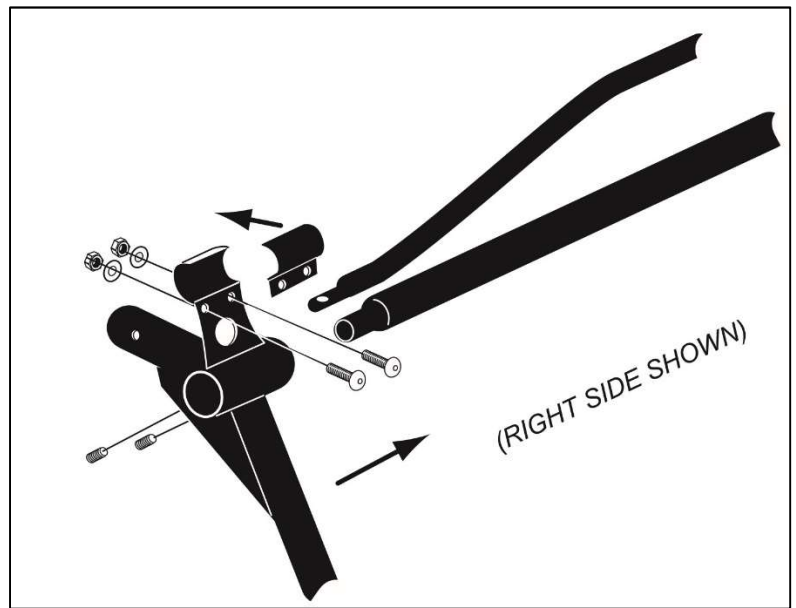

Step 3 – Attach Rear Legs

- Apply sealant to swaged tube per above guidelines.
- Use a 3/8" x 2-1/2" button head bolt, two 3/8" washers, and one 3/8" lock nut attach the REAR LEGS.
- Repeat process on opposite side.
- Remove excess sealant.

Note: The distance between front & rear legs will not be longer than the inside measurements of the bed itself.

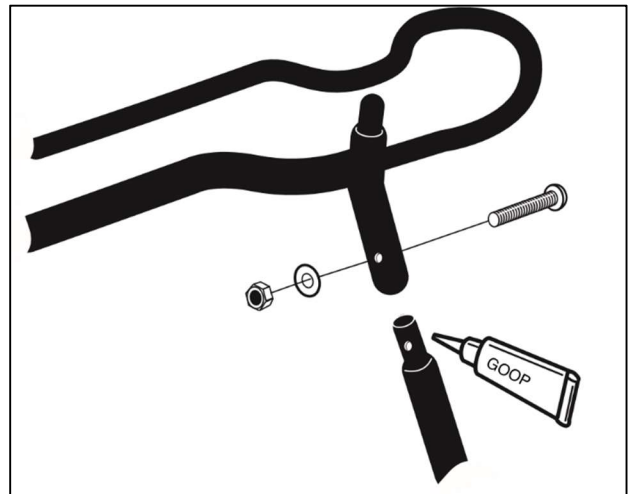

Step 4 – Install Center Crossbar

- Apply sealant to swaged tube per above guidelines and insert the CENTER CROSS BAR into the SIDE RAIL CUPS.
- Using 5/16" x 2-1/4" button head bolts, two 5/16" washers, and a 5/16" lock nut, attach crossbar to front legs.
- Repeat process on opposite side.
- Remove excess sealant.

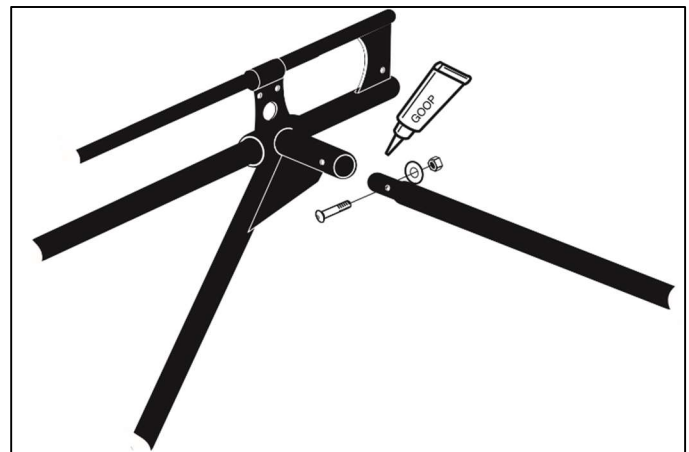

Step 5 – Install Rear Crossbar

- Insert PLASTIC CAPS onto the rear crossbar uprights, (the tall side of the tube).
- Using the provided clevis pin, slide the REAR CROSS BAR into the REAR LEG POSTS at the top, and secure as shown.

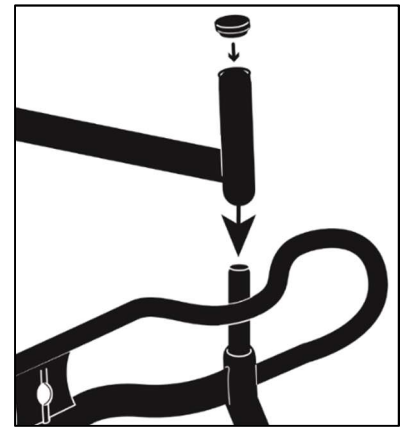

Step 6 – Install Front Crossbar

- Apply sealant to swaged tube per above guidelines to front side-channel swaged joint.
- Insert front side-channel swaged joint into front tube until bolt holes in tube and side-channel align.
- Using a 1/2" x 2-1/2" partially threaded button head screw, 1/2" washer, and 1/2" lock nut, loosely fasten front tube to side channel using.
- Remove excess sealant.
- Repeat process on opposite side.

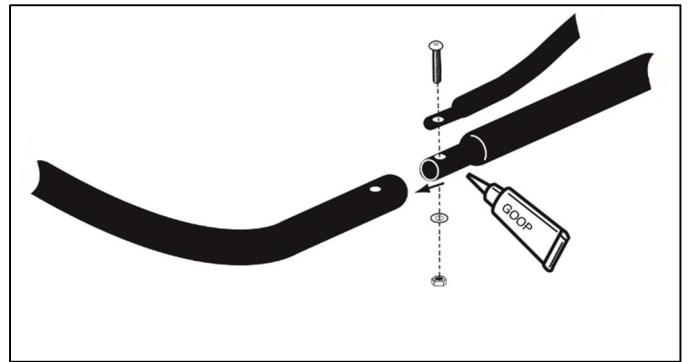

Step 7 – Attach Wind Deflector

- Position wind deflector on front U-tube.
- Insert wind deflector straps into slots on rear of wind deflector.
- Using #10 x 3/4" screws and #10 washers, bolt through top of wind deflector into press-in nuts on wind deflector straps.
- Tighten.

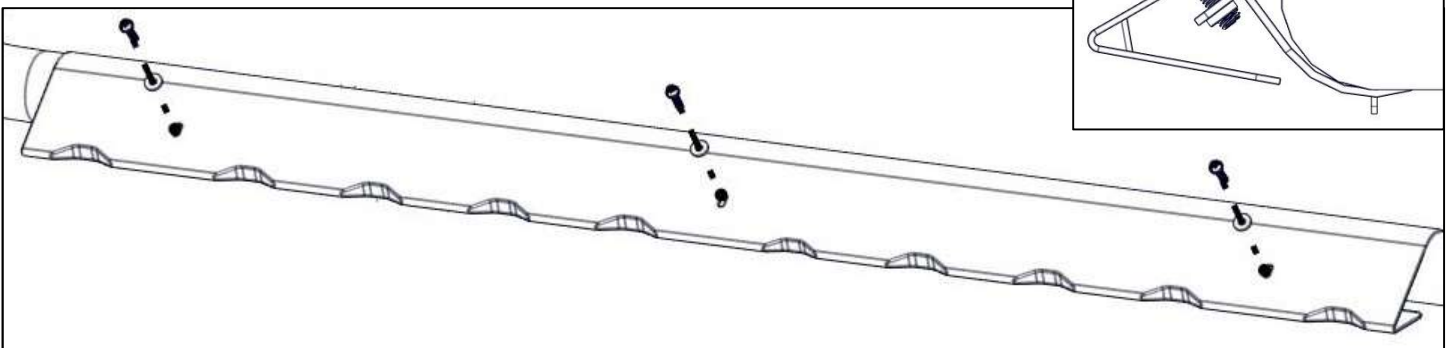
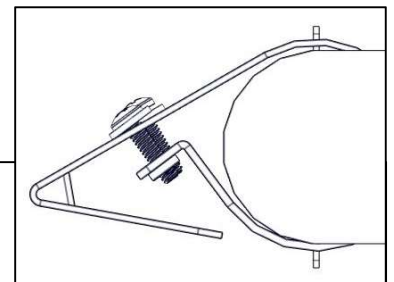
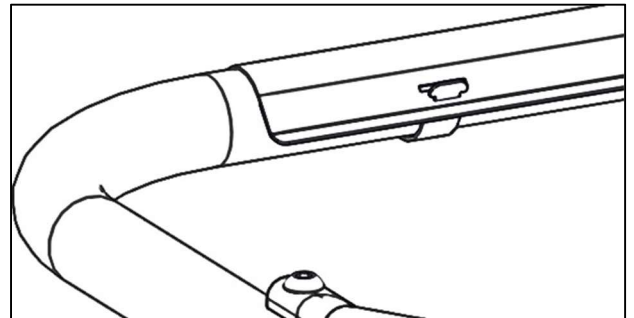

Step 8 – Attach Mounts

- Remove your camper shell from truck. Note whether there is a ridge on the bottom of your shell.
- Carefully insert the square tubing of the left supported mounting plate into the square tubing of the right supported mounting plate.

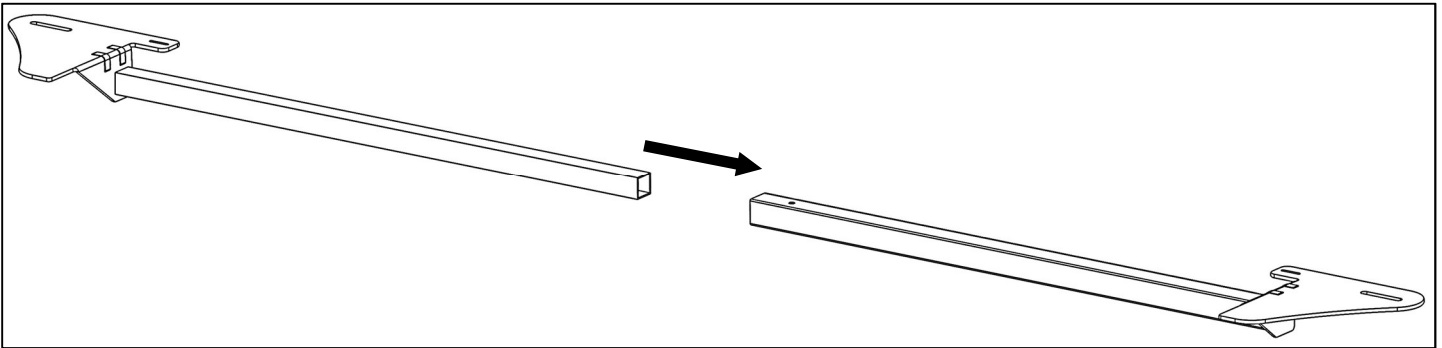
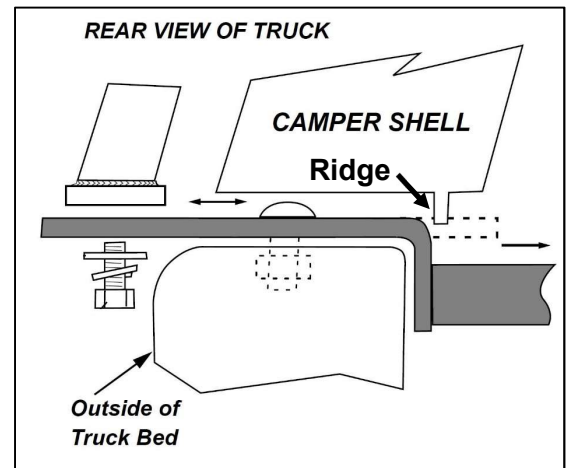

- Using 1/2" x 1-1/2" hex bolts, 1/2" lock washers, and 1/2" flat washers, bolt the supported mounting plates to the bottom of the front legs.
- Snug tighten but allow movement.

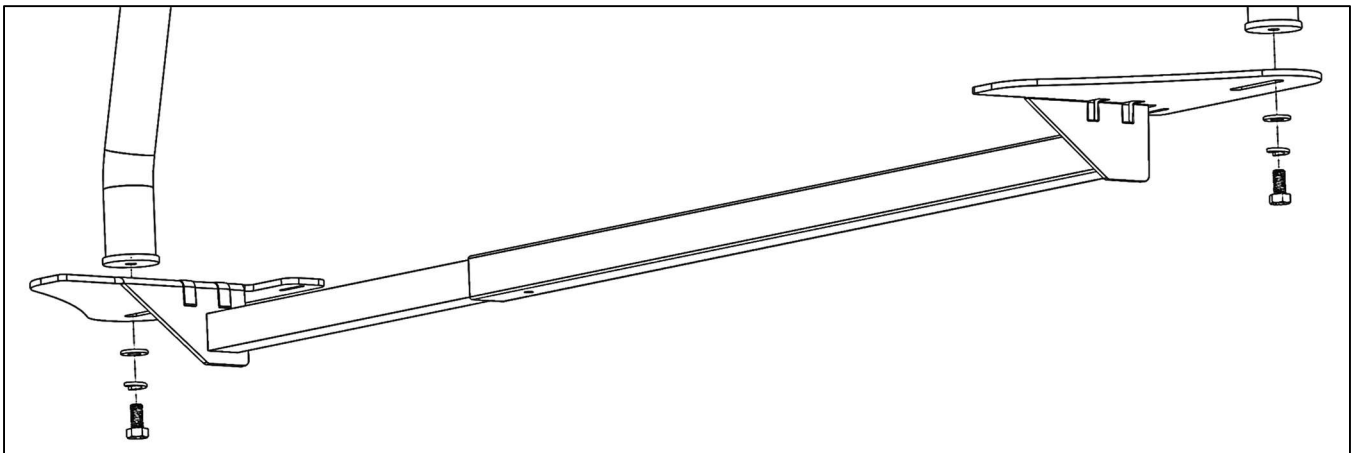

- Using 1/2" x 1-1/2" hex bolts, 1/2" lock washers, and 1/2" flat washers, bolt the rear mounting plates to the bottom of the back legs.
- Snug tighten but allow movement.

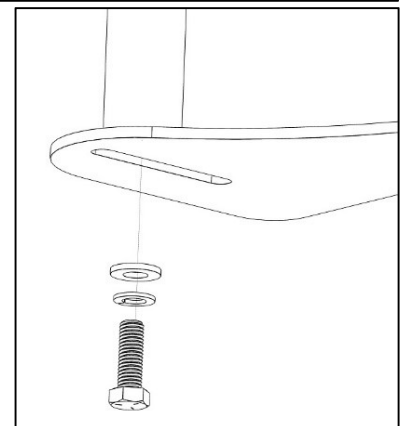

Step 9 – Mount Installation Preparation

- Position the rack on the truck as far forward as possible, with mounting plate tongue over the front bulkhead of the truck bed.
- Center the rack left to right on truck bed.
- Slide the front mount plates apart so that they are flush against opposite sides of the truck bed.

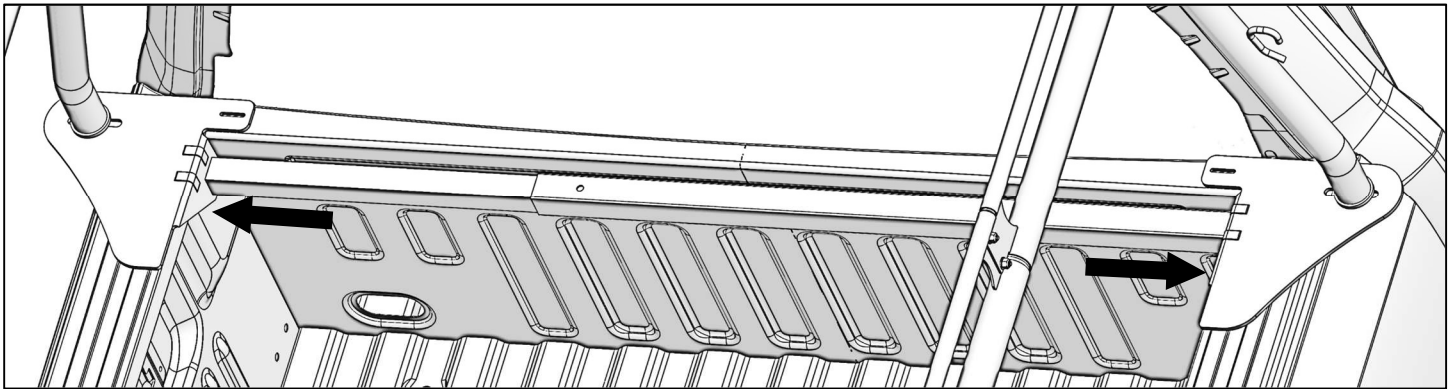
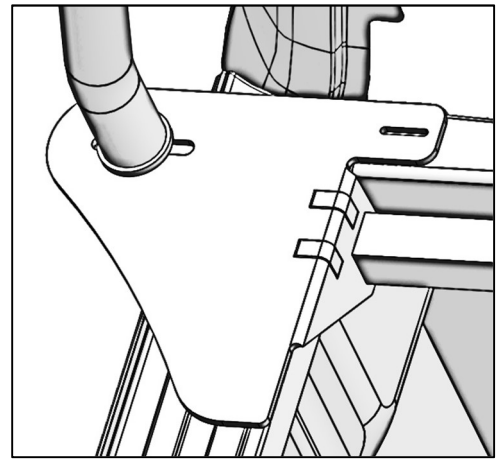

- Measure the inside dimension of the mount plates just above the support bar, and the outside dimension of the ridges (if any) on the bottom of your shell.
- It may be necessary to notch this ridge to avoid interference with the mount plates. Alternatively, you may want to notch the ridge front and back so that the mount plates can be slid in towards the center of the truck to minimize overhang.

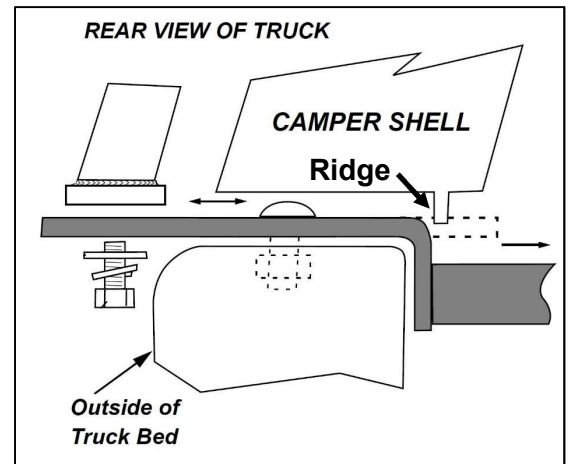

Bolt-through Mounting

- Make certain that the mount plates are square, flat, and horizontal with the bed rail. With the mount plates in their final position, locate and mark two optimal bolt hole locations on the top of each mount plate. The bolts should be located as far apart as possible, with clear access to the bolts, washers, and nuts underneath the truck's bedrail.

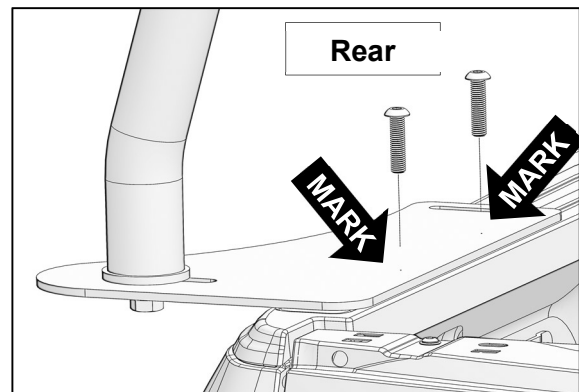
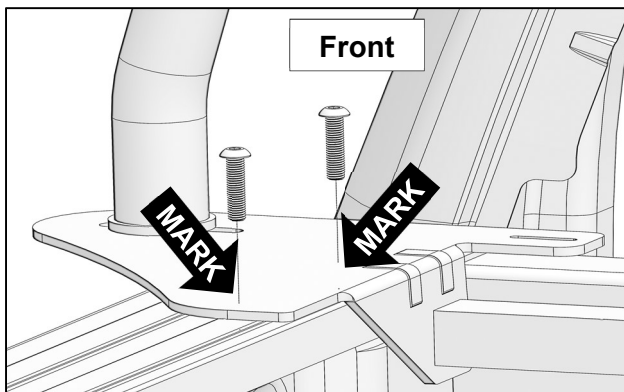

Stake Pocket Mounting

If the inside of your truck bed has a double wall and it is not possible to locate a bolt on the mounting plate nearest the leg, we recommend using our accessory **STAKE POCKET T-NUTS** to provide an **ADDITIONAL** attachment point.

- If the stake pocket is covered by plastic, remove plastic cap or cut out plastic.
- Locate center of stake pocket and mark location on top of mounting plate.

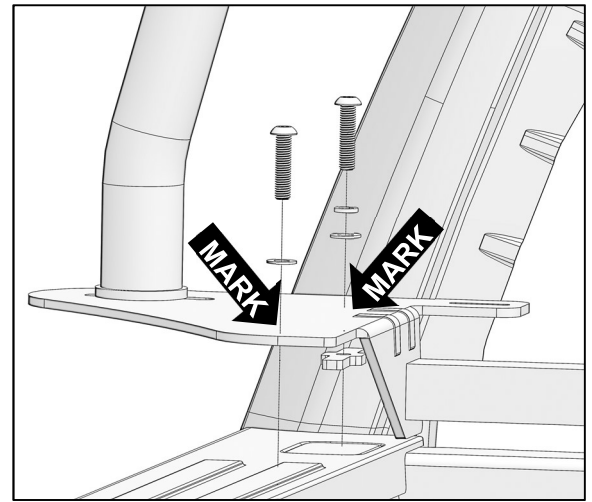

Step 10 – Mount Installation

- Remove rack from the truck, and remove the rear mounting plates and front support arm from rack.
- **CHECK TWICE - DRILL ONCE!**
- Drill 3/8" holes into the mounting plates using the previously marked locations.
- Set the mount plates back on the truck, in exactly the same location that they were before. Make certain each mount plate is square with the bed rail and dead horizontal. We recommend that you clamp each mount plate in position before drilling through the truck's bed rail.
- **CHECK TWICE - DRILL ONCE!**
- Drill through the bed using the holes in mount plates as guides.

Bolt-through Mounting

- Using 3/8" x 1-3/4" button head screw, 3/8" flat washers, and 3/8" lock nuts, bolt the mounting plates to the bed.
- Snug tighten but allow for movement. **DO NOT TIGHTEN** until all mounting bolts have been installed. It may be helpful to set the rack on the mounts to verify fitment before tightening hardware.

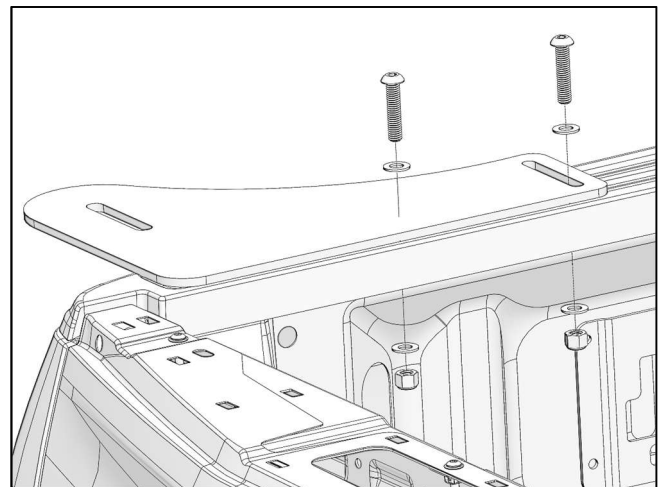
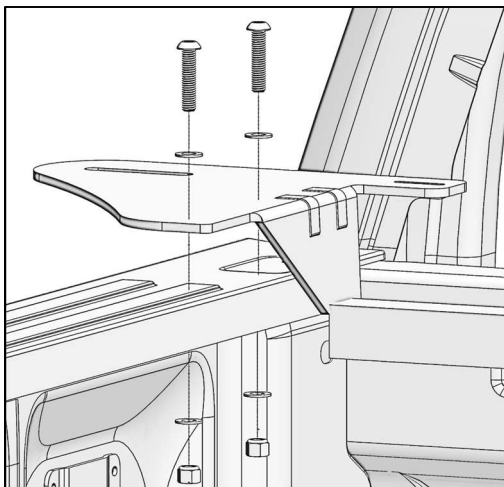

Stake Pocket Mounting

- If using the stake pocket installation, screw the 3/8" x 2-1/2" button head screw, and 3/8" flat washer, through drilled hole and then into t-nut.
- Insert the 3/8" t-nut into the stake pocket hole.
- With the front foot at the correct distance, snug tighten the 3/8" x 2-1/2" button head screw until the t-nut is bound beneath the metal stake pocket hole.
- Once mounts in correct position, **TIGHTEN ALL MOUNTING HARDWARE.**

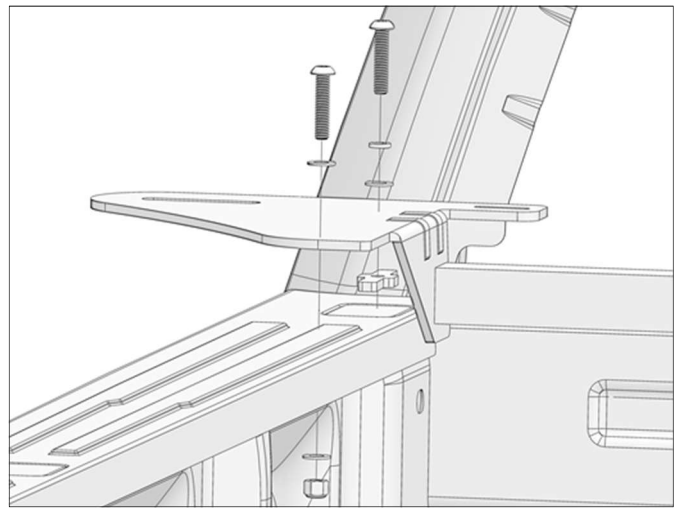

Step 11 – Bolt Inner Support Arm

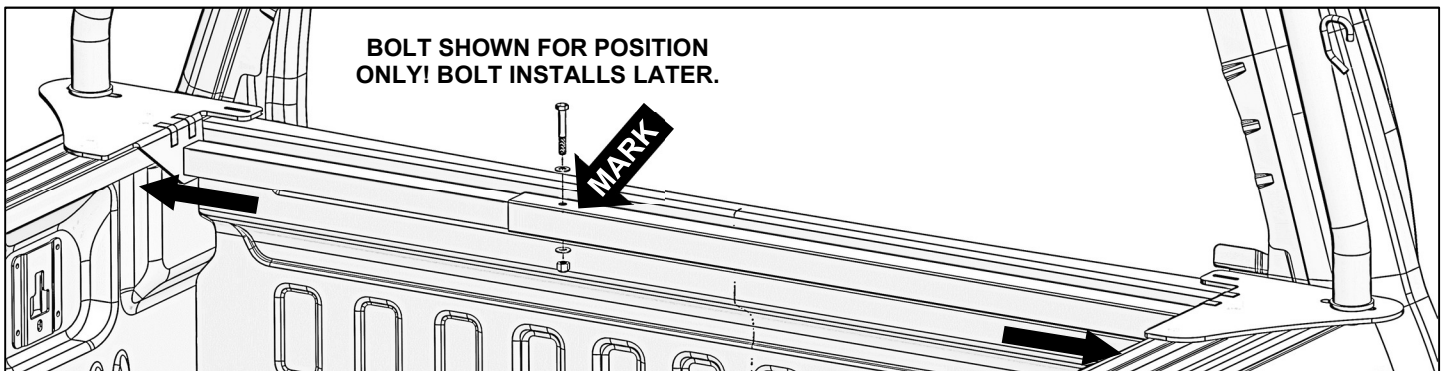

- With the front mount plates in position, mark the through bolt hole in the inner support arm.
- **CHECK TWICE - DRILL ONCE!**
- Punch hole centers in the locations that you have marked.
- Drill 3/8" holes in the inner support arm.
- Bolt the support arms together using a 3/8" x 2-1/4" button head screw two 3/8" flat washers, and a 3/8" lock nut.

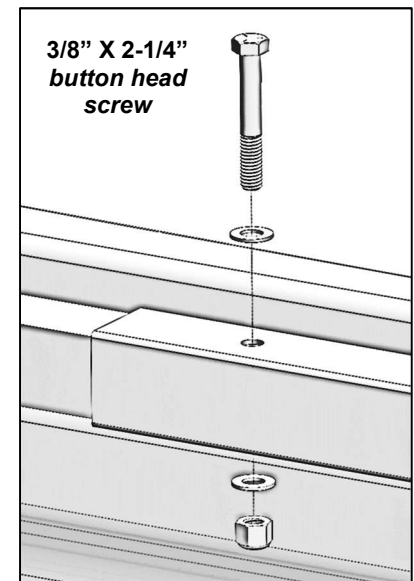

Step 12 – Adjusting Front Legs

- Adjust position of the front legs of the rack so that the distance between the center of the front legs and center of the back legs is equal to the distance between the centers of the mount plate slots determined in Step #2 above.
- Tighten the 5/16" set screws in the barrel of each front leg, and tighten top clamp nuts.
- Using a 1/2" x 1-1/2" hex head bolt, 1/2" washer, 1/2" lock washer place the rack on the mount plates, center, and attach rack to the mounting plates.



Step 13 – Attach Front Support Upright

- Using two 5/16" x 3/4" carriage bolts, two 5/16" washers and two 5/16" lock nuts attach the front SUPPORT UPRIGHT where the 1" tube begins to bend downward.
- Tighten down ALL NUTS AND BOLTS, EXCEPT LEG FOOTPLATES and CENTER CROSS BAR.

DO NOT OVER TIGHTEN ON DOUBLE WALL BED CONSTRUCTION, AS THIS MAY DEFORM THE SHEET METAL OF THE PICKUP BED!

- Center RACK over bed and tighten FRONT MOUNT BOLTS. On REAR MOUNT BOLTS, be sure LOCK PINS slide IN & OUT smoothly and freely before tightening the rear BOLTS.
- Snug bolts in CENTER CROSS BAR.

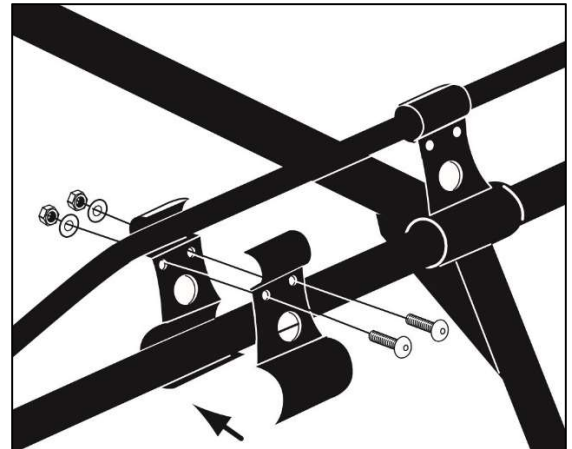

GO BACK AND TIGHTEN ALL HARDWARE.

INSTALLATION AND ASSEMBLY ARE COMPLETE.